



transport

Department:
Transport
REPUBLIC OF SOUTH AFRICA

ADMINISTRATIVE GUIDELINES FOR GRANTING OF EXEMPTION PERMITS FOR THE CONVEYANCE OF ABNORMAL LOADS

1st Edition

July 2009

Compiled by the Abnormal Loads Technical Committee (ALTC)
Published in July 2009 by the:
Department of Transport
Private Bag X193
PRETORIA
0001
REPUBLIC OF SOUTH AFRICA

Printed in the
Republic of South Africa

SYNOPSIS

The National Road Traffic Act (Act 93 of 1996) and the National Road Traffic Regulations, 2000 prescribe certain limitations on vehicle dimensions and axle and vehicle masses that a vehicle using a public road must comply with. However, certain vehicles and loads cannot be moved on public roads without exceeding the limitations in terms of the dimensions and/or mass as prescribed. Where such a vehicle or load cannot be dismantled, without disproportionate effort, expense or risk of damage, into units that can travel or be transported legally, it is classified as an abnormal load and is allowed to travel on public roads under an exemption permit issued in terms of Section 81 of the National Road Traffic Act.

This document describes the rules and conditions that apply to the transportation of abnormal loads and the operation of abnormal vehicles on public roads and the detailed procedures to be followed in applying for exemption permits.

TABLE OF CONTENTS

| | | |
|--------|--|------|
| 1. | Introduction..... | 1-1 |
| 1.1 | Background | 1-1 |
| 1.2 | Types of Abnormalities | 1-2 |
| 2. | Administration of Abnormal Vehicles and Loads | 2-3 |
| 2.1 | Role-Players and Responsibilities | 2-3 |
| 2.1.1 | Background..... | 2-3 |
| 2.1.2 | Permit Office | 2-3 |
| 2.1.3 | Law Enforcement Officers..... | 2-3 |
| 2.1.4 | Local Authorities | 2-4 |
| 2.1.5 | Transport Consultants..... | 2-4 |
| 2.1.6 | Consulting Engineers..... | 2-5 |
| 2.1.7 | Operator | 2-5 |
| 2.1.8 | Person in Charge | 2-5 |
| 2.1.9 | Driver..... | 2-5 |
| 2.1.10 | National Prosecuting Authority..... | 2-5 |
| 2.1.11 | Eskom & Telkom..... | 2-5 |
| 2.2 | Registration of Abnormal Vehicles..... | 2-6 |
| 2.2.1 | Background..... | 2-6 |
| 2.2.2 | Sequence Registration..... | 2-6 |
| 2.2.3 | Combination Registration..... | 2-7 |
| 2.2.4 | Validity of AV Registration | 2-8 |
| 2.2.5 | Well-balanced Combinations | 2-8 |
| 2.3 | Special Classification (NaTIS) | 2-8 |
| 2.3.1 | Background..... | 2-8 |
| 2.3.2 | Procedure..... | 2-8 |
| 2.4 | Dimensional and Mass Limitations applicable to Abnormal Load Vehicles..... | 2-9 |
| 2.5 | Marking and Escorting of Abnormal Load Vehicles | 2-9 |
| 2.6 | Speed Restrictions applicable to Abnormal Load Vehicles | 2-9 |
| 2.7 | Principle Approvals | 2-9 |
| 2.7.1 | Abnormal Vehicles | 2-9 |
| 2.7.2 | Abnormal Loads..... | 2-10 |
| 2.8 | Roadworthiness | 2-11 |
| 2.9 | Insurance | 2-11 |
| 3. | Abnormal Load Permits..... | 3-1 |
| 3.1 | Background..... | 3-1 |
| 3.2 | Types of Permits | 3-1 |
| 3.2.1 | Trip Permits..... | 3-1 |
| 3.2.2 | Area-period Permits..... | 3-1 |
| 3.2.3 | Route-period Permits | 3-2 |

| | | |
|-------|---|-----|
| 3.3 | Countrywide Permits..... | 3-3 |
| 3.4 | Permit Applications | 3-3 |
| 3.4.1 | Permit Application and Issuing Procedure..... | 3-3 |
| 3.4.2 | Application Documentation | 3-4 |
| 3.5 | Amendment of Exemption Permit | 3-4 |
| 3.6 | Cancellation of Exemption Permit..... | 3-4 |
| 3.6.1 | Conditions | 3-4 |
| 3.6.2 | Re-imbusement of Fees | 3-5 |
| 3.6.3 | Procedure..... | 3-5 |
| 3.7 | Embargo Days | 3-5 |
| 3.8 | Weekend Travel | 3-5 |
| 3.9 | Night Travel..... | 3-6 |
| 3.10 | Routes and Clearances | 3-6 |
| 4. | Fees..... | 4-1 |
| 4.1 | Background..... | 4-1 |
| 4.2 | Registration Fee..... | 4-1 |
| 4.3 | Administration Fee | 4-1 |
| 4.4 | Road Usage Fee | 4-1 |
| 4.5 | Mass Fee | 4-1 |
| 4.6 | Escorting Fee | 4-2 |
| 4.7 | Schedule of Fees | 4-2 |
| 4.8 | Normal Licensing Fee | 4-3 |
| 4.9 | Other Costs | 4-3 |
| 4.9.1 | Prevention of Damage to Structures..... | 4-3 |
| 4.9.2 | Fees for Temporary or Permanent Road Alterations, Diversion of Traffic and other Costs..... | 4-3 |
| 4.10 | Carriers Exempted from Fees..... | 4-4 |
| 5. | Permit Conditions | 5-1 |
| 5.1 | Introduction | 5-1 |
| 5.2 | Standard Permit Conditions | 5-1 |
| 5.3 | Control Certificate | 5-5 |
| 5.4 | Other Conditions | 5-6 |
| 6. | Specific policies..... | 6-1 |
| 6.1 | ISO Freight Containers | 6-1 |
| 6.1.1 | Principles..... | 6-1 |
| 6.2 | Mobile Cranes..... | 6-1 |

| | | |
|-------|-------------------------|-----|
| 6.2.1 | Principles..... | 6-2 |
| 6.3 | Recovery Vehicles | 6-2 |
| 6.3.1 | Principles..... | 6-2 |
| 6.4 | Extra Wide Loads..... | 6-3 |
| 6.4.1 | Principles..... | 6-3 |
| 6.5 | Car Carriers..... | 6-3 |
| 6.5.1 | Principles..... | 6-4 |

APPENDICES

| | | |
|-------------|---|----|
| Appendix A: | Permit Application Forms..... | A1 |
| Appendix B: | AV Registration Application Forms | B1 |
| Appendix C: | Permit Document Layout | C1 |

LIST OF TABLES

| | | |
|------------|--|-----|
| Table 2.1: | Vehicle Types that can be Registered in the AV Register..... | 2-6 |
| Table 3.1: | Validity Period for Trip Permits | 3-1 |
| Table 3.2: | Distances for Area-period Permits (km)..... | 3-2 |
| Table 4.1: | Abnormal Load/Vehicle Fee Items..... | 4-2 |
| Table 5.1: | Standard Permit Conditions | 5-1 |

LIST OF FIGURES

| | | |
|-------------|--|-----|
| Figure 2.1: | Examples of Vehicle Combinations used to Transport Abnormal Loads..... | 2-8 |
| Figure 3.1: | Permit Application and Issuing Procedure | 3-4 |

DEFINITIONS

| <i>Term</i> | <i>Definition</i> | <i>See also</i> |
|--|--|-------------------------------------|
| Abnormal load | An indivisible (for practical purposes) object that, due to its dimensions and/or mass, cannot be transported on a vehicle or vehicles without exceeding the limitations of the dimensions or mass as described in the National Road Traffic Regulations, 2000. | 1.1 |
| Abnormal vehicle | A vehicle or a combination of vehicles that, by virtue of its dimensions or mass, or a combination of both, does not comply with the requirements of the National Road Traffic Regulations, 2000. In Regulation 284 of the NRTR an abnormal vehicle is defined as: "Any vehicle which is operated under a written exemption granted in terms of section 81 of the Act and any motor vehicle accompanying such abnormal vehicle as a condition for operation." | 1.1 |
| Adapter dolly <i>(from NRTR)</i> | A semi-trailer with one or more axles, designed or adapted – (a) to be attached between a truck-tractor and semi-trailer, and (b) not to carry any load other than that imposed by semi-trailer. | Table 2.1 Sketch |
| Administrative Officer | A person appointed by the carrier and who, as far as the abnormal load or vehicle is concerned, is responsible for the conduct and operations of the carrier to whom a permit has been granted. | |
| Allowable | The maximum mass and dimensions, which the provincial authorities will allow in terms of the Guidelines. "Allowed" shall have a corresponding meaning. | |
| Articulated motor vehicle <i>(from NRTA)</i> | A combination of motor vehicles consisting of a truck-tractor and a semi-trailer. | |
| AVR Number | A reference number which has been allocated to a vehicle, or a combination of vehicles that has been entered in a Register of Abnormal Vehicles approved by the Provincial Authorities. | 2.2.3 |
| Axle <i>(from NRTR)</i> | In relation to a vehicle, means a device or set of devices, whether continuous across the width of the vehicle or not, about which the wheels of the vehicle rotate and which is so placed that, when the vehicle is travelling straight ahead, the vertical centre-lines of such wheels would be in one vertical plane at right angles to the longitudinal centre-line of such vehicle. | |
| Bridge | Any structure designed to carry vehicular traffic and which spans a gap of more than 6 m. In terms of the NRTA, a bridge includes a culvert and a causeway. | |
| Carrier | In the context of this document, means a person who undertakes the conveyance of abnormal loads by road for reward or in the course of his industry, trade or business by means of a motor vehicle. | |

| Term | Definition | See also |
|--|--|-------------------------------------|
| Converter dolly <i>(from NRTR)</i> | A trailer which has one or more axles and, when used in a combination with a semi-trailer, converts the semi-trailer into a trailer. | |
| Detail route | Turn by turn description of the intended route to be used for the conveyance of the abnormal load, with reference to street names and route numbers. | |
| Dolly | Any of the following: a) a steerable dolly; or b) a converter dolly; or c) an adapter dolly. | |
| Drawbar trailer | A trailer which is attached to a drawing vehicle by a drawbar. | |
| Driver | In addition to the definition contained in the National Road Traffic Act, any person who controls or activates the steering mechanism of any steerable axle or axle unit of a trailer or semi-trailer. | 2.1.10 |
| Dual tyre spacing | The distance from the centre of the tread of one tyre to the centre of the tread of the closest tyre similarly mounted on an axle. | |
| Dual wheel | Two tyres, mounted on separate rims, rigidly attached to each other on an axle. | |
| Effective width | The dimension used in calculating loads on bridges, and is determined by adding 1,2 m to the width of a vehicle measured to the outside of the tyres. If the distance between adjacent tyres exceeds 1,2 m, such excess must be deducted from the effective width. | |
| Escort | A person in a separate escort vehicle accompanying an abnormal load/vehicle for the purpose of assisting other road users and giving timely warning of the presence of an abnormal load/vehicle. | |
| Equivalent single wheel mass (ESWM) | The isolated single-wheel load which, operating at 520 kPa cold tyre pressure would produce the same effect in a particular road pavement as that produced by all the wheels in that group. | |
| Extendable semi-trailer | A semi-trailer constructed with a telescopic chassis to enable the overall length and wheelbase to be increased as required. | Table 2.1 Sketch |
| Fifth wheel | A device fitted to a truck-tractor, adapter or converter dolly in order to permit articulation between the said unit and a semi-trailer. | |

| Term | Definition | See also |
|---|--|-----------------|
| Front overhang <i>(from NRTR)</i> | In relation to a vehicle means that portion of the vehicle, excluding any drawbar or coupling, which projects in front of the centre-line of the front axle or the foremost axle of the front axle unit or, if such vehicle has only one axle, which projects in front of the centre-line of that axle, or in the case of a semi-trailer, which projects in front of the centre-line of the kingpin: Provided that any portion of a semi-trailer which projects in front of its front end or anything attached to a semi-trailer in front of its front end and which is within an area formed by drawing, with the king-pin as centre, an arc connecting the extreme points of the front end of the semi-trailer, shall not be deemed to be part of the front overhang of such semi-trailer; | |
| Gross | There are several definitions in the NRTA and the NRTR which include the word "gross". In all cases the word "gross" refers to the manufacturer's rating, e.g. Gross Axle Massload (GA) refers to the maximum massload of the particular axle as specified by the motor vehicle manufacturer. | |
| Gross combination mass (GCM) <i>(from NRTA)</i> | In relation to a motor vehicle which is used to draw any other motor vehicle, means the maximum mass of any combination of motor vehicles, including the drawing vehicle, and load as specified by the manufacturer thereof or, in the absence of such specification, as determined by the registering authority. | |
| Gross vehicle mass (GVM) <i>(from NRTA)</i> | In relation to a motor vehicle, means the maximum mass of such vehicle and its load as specified by the manufacturer thereof or, in the absence of such specification, as determined by the registering authority. | |
| Guidelines | These Administrative Guidelines for Granting of Exemption Permits for the Conveyance of Abnormal Loads, developed by the Abnormal Loads Technical Committee, which derives its mandate from the Roads Co-ordination Body (RCB), which reports to the Committee of Transport Officials (COTO). | |
| Indivisible load | A load which cannot, without disproportionate effort, expense or risk of damage, be divided into two or more loads for the purpose of transport on public roads. | |
| Kingpin | The attaching pin on semi-trailer or adapter dolly which matches the fifth wheel on the truck-tractor, adapter or converter dolly, coupling the vehicles together. | |
| Laden mass | Laden mass includes the unladen mass and the payload. | |
| Load projection | This is the portion of the load that extends forward beyond the front end of the vehicle or rearward beyond the rear end of the vehicle. | |
| Mass | The quantity of matter which a body contains, irrespective of its bulk or volume. It is measured in kilograms in the SI system of measurement. | |

| Term | Definition | See also |
|---|--|-------------------------------------|
| MEC <i>(from NRTA)</i> | A member of the Executive Council appointed in terms of section 132 of the Constitution of the Republic of South Africa, 1996 (Act No. 108 of 1996), and who is responsible for road traffic matters, or any other person authorised by him or her to exercise any power or perform any duty or function which such MEC is empowered or obliged to exercise or perform in terms of this Act. | |
| Mobile crane | A self-propelled machine specially designed for lifting loads. Mobile cranes can be placed in the following three classes: 1. Centre mounted (rough terrain) mobile cranes; 2. Truck mounted mobile cranes; and 3. All terrain mobile cranes.. | Table 2.1 Sketch |
| Modular trailer | A towed vehicle composed of inter-connectable and interchangeable modules. Modules can be different in size and can be coupled in a variety of combinations. | Table 2.1 Sketch |
| Multi-axle trailer | A trailer with multiple axles either evenly distributed under the loading deck or in a front and rear group. The axles are steerable and the trailer is attached to the drawing vehicle by a towbar or a variable gooseneck. | Table 2.1 Sketch |
| National Road Traffic Act (NRTA) | The National Road Traffic Act, 1996 (Act 93 of 1996), as amended. | |
| National Road Traffic Regulations (NRTR) | The National Road Traffic Regulations, 2000, as amended, made under Section 75 of the NRTA. | |
| Operator <i>(from NRTA)</i> | Means the person responsible for the use of a motor vehicle of any class contemplated in Chapter VI (of the NRTA), and who has been registered as the operator of such vehicle. | 2.1.8 |
| Payload | The mass of those goods being carried by the vehicle or combination of vehicles, the transport of which from one place to another is the purpose for which the journey is being undertaken, and includes any special equipment required for securing a particular load. | |
| Permissible | The maximum dimensions and mass of vehicles or combination of vehicles permitted in terms of the NRTR. | |
| Permit | An exemption permit issued by a Provincial Roads Authority in terms of Section 81 of the NRTA, authorising the transportation of an abnormal load or the movement of an abnormal vehicle or a combination of vehicles subject to such terms and conditions and the payment of such fees as may be imposed. | 3 |

| Term | Definition | See also |
|--------------------------------------|---|---------------------|
| Person in charge | The person appointed by the carrier operating an abnormal vehicle or operating a vehicle carrying an abnormal load, to accompany such a vehicle or load in order to supervise operations and ensure compliance with the permit conditions. This person must assume full responsibility on behalf of the carrier while the vehicle is on the road. | 2.1.9 |
| Power/mass ratio | The ratio between the net power of the engine(s) in the hauling vehicle(s) and the gross mass of the vehicle(s) or combination of vehicles. | |
| Principle approval | Approval that is obtained by a manufacturer or importer of a vehicle (or load) prior to commitment to import or manufacture in order to obtain assurance that the vehicle (or load) would be granted exemptions to travel on a public road in future. | 2.7 |
| Rear overhang (from NRTR) | In relation to a vehicle, means that portion of the vehicle which projects to the rear of the centre-line of the rear axle or the rearmost axle of the rear axle unit or, if such vehicle has only one axle, which projects to the rear of the centre-line of that axle. | |
| Register of abnormal vehicles | A record of abnormal load vehicles, details of which have been submitted to, and which have been accepted by the Provincial Authorities as being suitable for the conveyance of abnormally heavy loads. | 2.2 |
| Rigid vehicle | A single vehicle with two or more axles or groups of axles operating independently. | |
| Road Usage Factor (RUF) | The Road Usage Factor is a factor calculated from the overall length and overall width of the vehicle to give an indication of the warning devices and escorts that are required when the vehicle travels on a public road. | |
| Route Clearance | A statement by a registered professional engineer with structural as well as road safety and traffic engineering competencies, to the effect that the detail route provided was inspected by him/her and is safe for the transportation of the intended abnormal load. It must include the vehicle configuration and unit loading used in his/her calculations as well as a list of all structures along the route and when they were inspected. The engineer responsible for the route clearance carries the full risk with regard to claims and structural failures and as such must have adequate professional indemnity insurance to cover that risk. | |
| Self-supporting load | A load which, because of its design and construction, is used as part of the structure of the vehicle or combination of vehicles on which it is transported. | |
| Semi-trailer (from NRTR) | A trailer having no front axle and so designed that at least 15 per cent of its tare is super-imposed on and borne by a vehicle drawing such trailer. | Table 2.1 Sketch |

| Term | Definition | See also |
|--|---|-------------------------------------|
| Sequence number | A reference number which has been allocated to a single vehicle or to a component vehicle of a combination and which has been entered in the Register of Abnormal Vehicles by the Provincial Authorities. | 2.2.2 |
| Stability check | Calculations performed by a registered professional engineer to determine the stability angle, safe traveling speed as well as safe wind speed in order to establish if an abnormal load may be safely carried on a particular vehicle. Centre of gravity of the vehicle, the load and the combined centre of gravity of the laden vehicle as well as all assumptions that the calculations were based upon, need to be shown. | |
| Steerable axle | An axle which may be steered either manually or automatically. A steerable axle group is steerable in the sense that it is capable of moving the vehicle laterally in a controlled manner. | |
| Steerable dolly | A trailer, with one or more axles (of which at least one must be steerable), designed or adapted generally or specifically for supporting the rear end of a self-supporting load and equipped with a turntable to enable it to pivot. | Table 2.1 Sketch |
| Tag axle | A non-powered, independently-suspended axle in an axle unit. | |
| Tare (from NRTA) | In relation to a motor vehicle, means the mass of such vehicle ready to travel on a road and includes the mass of— a) any spare wheel and of all other accessories and equipment supplied by the manufacturer as standard for the particular model of motor vehicle concerned; b) anything which is a permanent part of the structure of such vehicle; c) anything attached to such vehicle so as to form a structural alteration of a permanent nature; and d) the accumulators, if such vehicle is self-propelled by electrical power, but does not include the mass of— i) fuel; and ii) anything attached to such vehicle which is not of the nature referred to in paragraph (b) or (c). | |
| Tracking over bridges | Travelling along a path over a bridge which minimizes overstressing of the structure. | |
| Traffic officer (from NRTA) | A traffic officer is defined in the Road Traffic Act, Act 29 of 1989 as follows: “Traffic officer means a traffic officer appointed under section 3 and any member of the Force as defined in section 1 of the Police Act, 1958 (Act no 7 of 1958) and for the purpose of Chapters IV, VI, VII and VIII and sections 131 and 135 of this Act includes a peace officer”. | |

| Term | Definition | See also |
|---|--|-------------------------------------|
| TRH 11 | A document, published by the Committee of Transport Officials (COTO), containing the dimensional and mass limitations and other requirements for abnormal vehicles, developed by the Abnormal Loads Technical Committee, which derives its mandate from the Roads Co-ordination Body (RCB), which reports to COTO. | |
| Truck-tractor <i>(from NRTA)</i> | A motor vehicle designed or adapted— a) for drawing other vehicles; and b) not to carry any load other than that imposed by a semi-trailer or by ballast, but does not include a tractor. | Table 2.1 Sketch |
| Turning radius <i>(from NRTR)</i> | Turning radius in relation to a vehicle, means the radius of the circle described by the outer steered wheel of a vehicle when such wheel is deflected as far as possible from the straight, either to the left or to the right, and, where the radii so obtained are not the same, the larger of the two shall be taken as the turning radius of the vehicle, the radius being measured to the outer edge of the track described by such outer steered wheel. | |
| Unladen mass | In relation to a vehicle or combination of vehicles, means the mass of such a vehicle or combination of vehicles when ready to travel on a road, and includes a) the tare; b) the mass of the fuel when the tanks are full; c) the mass of the driver and any other personnel carried; and d) the mass of any other accessories and equipment normally carried, but excludes the payload. | |
| Wheelbase <i>(from NRTR)</i> | a) in relation to a semi-trailer, means the distance measured at ground level, between parallel planes at right-angles to the longitudinal centre-line of the vehicle passing through the centre-line of its king-pin and the centre-line of its axle or axle unit, as the case may be; b) in relation to a trailer with only one axle or one axle unit, other than a semi-trailer, means the distance, measured at ground level, between parallel planes at right angles to the longitudinal centre-line of the vehicle passing through the centre-line of the coupling pin or knuckle and the centre-line of such axle or axle unit as the case may be; and c) in relation to any other vehicle, means the distance measured at ground level between parallel planes at right-angles to the longitudinal centre-line of the vehicle passing through the centre-line of the front axle or front axle unit and the centre-line of the rear axle or rear axle unit, as the case may be. | |
| Wheeltrack | The measurement to the outside of the outer wheels of the load carrying axles of a vehicle. | |

1. INTRODUCTION

1.1 Background

The National Road Traffic Act (Act 93 of 1996) (herein referred to as the NRTA) and the National Road Traffic Regulations, 2000 (herein after referred to as the NRTR), prescribe certain limitations on vehicle dimensions and axle and vehicle masses that a vehicle using a public road must comply with. However, certain vehicles and loads cannot be moved on public roads without exceeding the limitations in terms of the dimensions and/or mass as prescribed in the NRTR. Where such a vehicle or load cannot be dismantled, without disproportionate effort, expense or risk of damage, into units that can travel or be transported legally, it is classified as an abnormal load. Provision for such abnormal vehicles and loads is made in the NRTA, and specifically in Section 81¹ of the NRTA, which reads as follows:

“Vehicle and load may be exempted from provisions of Act

81. (1) The Minister may, after the applicant has paid the fees or charges referred to in section 7(3) and subject to such conditions as he or she may determine, authorise in writing, either generally or specifically, the operation on a public road of a vehicle which, due to such vehicle’s original design cannot comply with this Act.

(2) The MEC may, after the applicant has paid the fees or charges referred to in section 7(3) and subject to such conditions as he or she may determine, authorise in writing, either generally or specifically, the conveyance in a safe manner on a public road of passengers or any load otherwise than in accordance with this Act.

(3) An MEC shall determine the fees or charges payable for a vehicle or load that does not comply with this Act.”

When the movement of an abnormal load is considered to be in the economic and/or social interest of the country, an exemption permit may be issued to allow a vehicle(s) transporting such an abnormal load to operate on a public road for a limited period.

This document deals with the administrative procedures relating to the registration of abnormal vehicles and the application to or issuing of exemption permits.

These guidelines must be read with reference to TRH11: “Dimensional and Mass Limitations and Other Requirements for Abnormal Vehicles”.

The fundamental principles guiding this process are:

- An exemption permit for an abnormal load will only be considered for an indivisible load, abnormal in dimension and/or mass, where there is no possibility of transporting the load in a legal manner;
- The damage to the road infrastructure by an abnormal vehicle has to be recovered from the carrier;
- The risks to other road users must be reduced to a level equivalent to what it would be without the presence of the abnormal vehicle on the road; and
- The conditions imposed must take the economic and/or social interest of the country and public at large into account.

¹ As substituted by Section 23 of Act 64 of 2008: National Road Traffic Amendment Act, 2008

- The purpose of the exemption permit system is not to undermine or circumvent the NRTA and the NRTR.
- This document provides guidelines that are generally applicable, but the issuing authority can deviate from these guidelines and/or impose additional requirements when taking the circumstances applicable to each application into account.

1.2 Types of Abnormalities

A vehicle or a vehicle with its load that is considered to be indivisible can be abnormal in terms of dimensions or mass or both.

(a) Dimension Abnormality

A vehicle/combination is dimensionally abnormal when any of the following dimensions exceeds the legal limitations:

- Length
- Width
- Height
- Overhangs
- Load projections
- Wheelbase

(b) Mass Abnormality

When the allowable mass of the vehicle/combination or one or more axle groups exceeds the legal limitations, a mass abnormality exists.

2. ADMINISTRATION OF ABNORMAL VEHICLES AND LOADS

2.1 Role-Players and Responsibilities

2.1.1 Background

In view of the additional risk involved in the movement of abnormal vehicles and their loads, it is essential that particular attention be paid to the personnel operating abnormal vehicles and the other role players involved, to the vehicles themselves and to obtain insurance against expenses incurred in case of damage to public property.

2.1.2 Abnormal Loads Technical Committee

The Abnormal Loads Technical Committee (ALTC) is a national technical committee with the aim to promote and coordinate the management of adjudicating and processing applications for exemptions in terms of Section 81 of the NRTA. The ALTC therefore plays an important ongoing role in setting guidelines, fees and standards on behalf of the Minister of Transport and the relevant MEC's responsible for transport. The Terms of Reference for the ALTC are included in this document as Appendix D.

2.1.3 Permit Office

The permit office manages the registration of abnormal vehicles and the issuing of exemption permits for the conveyance of abnormal loads through the various provinces. The staff in the permit office includes both technical and administrative personnel.

(a) Engineer/Technical Person

The engineer or technical person is responsible for the registration of over mass vehicles or vehicle components/combinations that will be used to transport over mass loads. In addition, applications for permits that exceed certain limitations in terms of mass and/or dimensions may need technical evaluation before permission is granted to issue the permit. The engineer or technical person is responsible for this evaluation and may request additional information from the carrier to complete the evaluation. Information such as stability calculations and/or route clearances may be requested for larger loads.

(b) Administrative Personnel

Administrative personnel are responsible for the issuing of permits, amendments to permits, cancellation of permits and any other administrative tasks involved in the daily running of the permit office.

2.1.4 Law Enforcement Officers

Traffic officers are at all times, and in spite of exemption permits that may have been issued, responsible for the safety of the road-using public and may at their discretion suspend activities deemed to be dangerous or potentially damaging to road infrastructure.

It is compulsory for the driver of a vehicle transporting an abnormal load, to have the permit available within the vehicle. Traffic officers must check that the permit document bears an original stamp and signature of a provincial permit/traffic office. The permits must further be checked to ensure that all permit conditions are complied with. The permit will state the exact

abnormality that is permitted with regard to dimensions and allowable masses. When checking the exemption permit, particular attention should be given to:

- The registration number/s of the mobile crane or combination of vehicles;
- The period of validity;
- The description of the load (if any);
- The route;
- The dimensions of the vehicle and the load (if any);
- The condition of the vehicle (check for the condition of the tyres, the safety of the load, presence of oil leaks, whether the hydraulic control pipes are connected, etc); and
- Compliance with other conditions, such as maximum allowable speed, presence of escorting vehicles, warning lights and flags, permission to travel after dark or over weekends, etc.

The permit becomes invalid if any permit condition is not complied with. After a permit is declared to be invalid due to non-compliance with mass and/or dimension requirements, the abnormal vehicle or vehicles transporting abnormal loads should, as far as possible, be weighed and measured and charged based on the normal permissible masses and/or dimensions, as applicable. If the permit becomes invalid due to non-compliance with any other permit condition, charging should take place as appropriate.

Once a permit has been declared to be invalid, the traffic officer should prohibit the further operation of these vehicles or combination of vehicles on a public road. The carrier must then be allowed to rectify the non-compliance if possible, or to apply for a permit to proceed legally. In cases where the permit is declared invalid due to the vehicle not being on the approved route, a new permit will always have to be applied for. This permit can be obtained from the permit office in the province where the vehicle was apprehended. However, prior to granting such a permit, the recommendation of the charging officer has to be obtained. Such a permit does not prevent a traffic officer from proceeding with the normal prosecution for the offence that was committed before the permit was granted. The cost of such a permit will be calculated on the full distance of the journey from the original origin to the final destination.

2.1.5 Local Authorities

Where applicable, local authorities manage the conveyance of abnormal loads through municipal areas on the roads for which they are responsible to ensure that their infrastructure is not damaged.

(a) Municipal Traffic Department

The traffic department will supply municipal escorts to manage traffic when necessary.

(b) Municipal Services Manager (Electricity Department)

Personnel from this department will travel with the load and lift overhead lines when necessary.

2.1.6 Transport Consultants

Transport consultants are familiar with the rules that apply to the conveyance of abnormal loads. They may:

- Apply for exemption permits on behalf of the carriers and

- Ensure that the requirements of the authorities are being conveyed to the carriers.

2.1.7 Consulting Engineers

Consulting engineers are usually involved in the conveyance of the 'bigger' abnormal loads and superloads. Their involvement could include one or more of the following:

- Capacity calculations of vehicles and combinations of vehicles;
- Route clearances for loads where the total combination mass exceeds 125 000 kg with special reference to bridge limitations; or
- Stability calculations for high and wide loads.

2.1.8 Operator

- Full responsibility for the application of the permit and compliance with the permit conditions, lies with the carrier even if represented by an agent;
- Must comply with the applicable duties of an operator as stipulated in Section 49 of the NRTA;
- Must be registered with the Provincial Authorities as the operator;
- Must be able to certify that the driver is qualified to drive the vehicle and
- Must appoint a responsible person, who could be the driver, to accompany the load and must ensure that this person understands and complies with the permit conditions (person in charge).

2.1.9 Person in Charge

- Must be conversant with the conditions of the permit.

2.1.10 Driver

- Must have an unendorsed driver's licence of the appropriate category; and
- Must be in possession of a professional driving permit as required in terms of Section 32 of the NRTA.

2.1.11 National Prosecuting Authority

Prosecute those companies that transgress the law by:

- Transporting abnormal loads without an exemption permit;
- Operating contradictory to the conditions that are imposed by a valid exemption permit; or
- Supplying information to obtain an exemption permit that is not a true reflection of the reality.

2.1.12 Eskom & Telkom

Eskom and Telkom must ensure that their infrastructure will not cause a safety risk during the transportation of loads exceeding 5,8 m (Eskom) and 5,5 m (Telkom) in height respectively.

Eskom and Telkom will escort a vehicle in cases where the load is extremely high and the route cannot be cleared by either of them. These escorts will travel with the load and lift overhead lines when necessary.

2.2 Registration of Abnormal Vehicles

2.2.1 Background

Vehicles used for the conveyance of abnormally heavy loads as well as overweight mobile cranes have to be approved by the permit office and entered in a "Register of Abnormal Vehicles and Vehicles Used for Conveyance of Abnormal Loads" (AV Register). When a vehicle is altered in any way, or ownership changes, or the operator is changed, it must be re-registered and such changes be reflected in the AV Register.

Before a vehicle is entered in the AV Register, its owner must submit full details of the vehicle to the relevant permit office and, if required, calculations of its load capacity. The permit office will require the vehicle to be inspected by an engineer or technical representative of the permit office. If compliant, the vehicle will then be entered in the AV Register for that province and a sequence number and/or an AV number will be allocated to it. The owner will be advised as to the maximum load for which a permit will normally be granted.

Vehicles are normally AV registered in the province where they are licensed. When the need arises, registration may be done in another province. In the case of an articulated vehicle the registration of the trailer takes precedence. Any re-registration is fully charged for except when such re-registration is forced on the owner by the authorities such as by changing the number plate system.

The object of granting permits is not to extend the capacity of normal vehicles. When a load can be carried legally (or with a lesser degree of abnormality) by using a more suitable vehicle, then permits (and registration of vehicles) will not be permitted. Trailers with tandem axles or truck-tractors with single rear axles will therefore not be AV registered.

2.2.2 Sequence Registration

All component vehicles, i.e. truck tractors, dollies, semi-trailers and trailers or other types of abnormal vehicle will initially be registered separately and be referred to by their licensed registration numbers and by a sequence number. A registration fee will be levied for sequence registrations. The application for registration is done on the application forms included in Appendix B.

For conventional articulated vehicles, standard forms may be obtained from the relevant issuing authority and these forms must be completed and submitted by the owner or his agent. For unconventional vehicles these forms cannot be used, but full details of the vehicle's allowable loads must nevertheless be submitted with a schematic sketch of the vehicle showing all the vital dimensions.

The following vehicle types can be registered for use in overweight abnormal load transport under mass exemption:

Table 2.1: Vehicle Types that can be Registered in the AV Register

| Type | Example | Application Form |
|------|---------|------------------|
|------|---------|------------------|

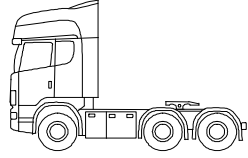
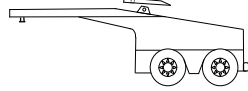
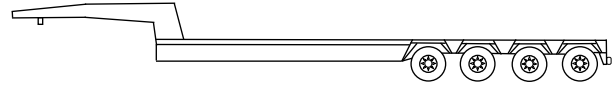
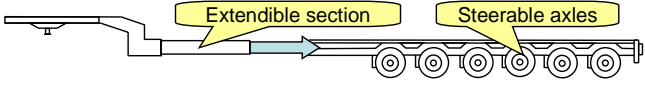
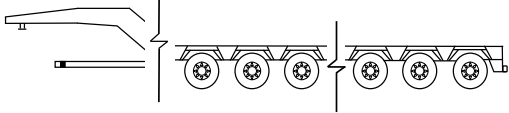
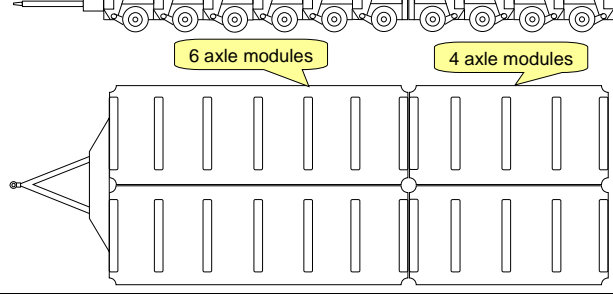
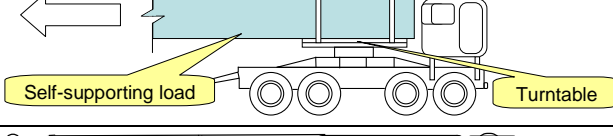
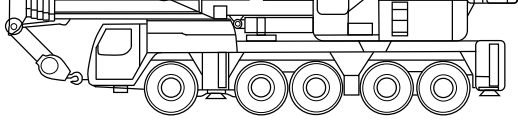
| Type | Example | Application Form |
|-------------------------|--|---------------------------------------|
| Truck tractor |  | Appendix B Truck tractor form |
| Dolly |  | Appendix B Dolly form |
| Semi-trailer |  | Appendix B Semi-trailer form |
| Extendible semi-trailer |  | Appendix B Semi-trailer form |
| Multi-axle trailer |  | Appendix B Multi-axle trailer form |
| Modular trailer |  | |
| Steerable dolly |  | |
| Mobile crane |  | Appendix B Mobile crane form |

2.2.3 Combination Registration

A specific combination of vehicles is analysed and the combination is allotted an “AV number.” The particulars and the limits of usage of such vehicles and combinations of vehicles are recorded in the AV register. Sequences from different provinces can be combined into AV combinations. Any semi-trailer or trailer may be matched with a number of truck tractors of the same or better specification as stated on the registration sheet under the same AV registration number.

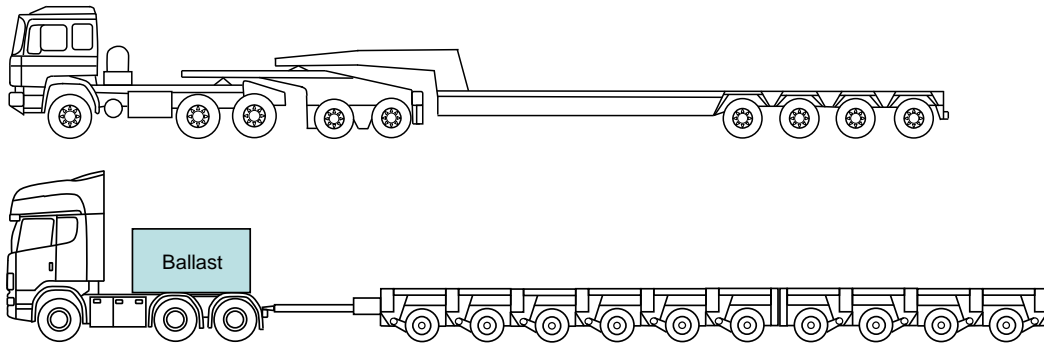

Figure 2.1: Examples of Vehicle Combinations used to Transport Abnormal Loads

2.2.4 Validity of AV Registration

The registration of all vehicles in the Abnormal Vehicle Register must be renewed every five years in order to keep the register current and to reflect changes and alterations made to such vehicles. A combination registration will be valid while all individual vehicles in the combination are valid. A registration fee will be levied for sequence re-registrations.

2.2.5 Well-balanced Combinations

A combination is well-balanced when the load carrying capacities of the individual components are closely matched. In general, no combination will be registered if the payload capacity of the combination is less than 50 per cent of the payload capacity of the trailer or semi-trailer.

2.3 Special Classification (NaTIS)

2.3.1 Background

All vehicles have to be registered on NaTIS (National Traffic Information System), irrespective of the intention to use them on public roads or not. In terms of Regulation 21(1)(g) in the NRTA, a vehicle, which may only be operated on a public road under an exemption permit, may be specially classified in relation to the payment of licence fees. These vehicles are then registered as such on NaTIS and are liable for substantially reduced license fees. If the special classification is abused the vehicle will lose the special status, the owner will be held accountable for the full licence fees over the period since special classification and the vehicle will have to be modified to conform to the Road Traffic Act.

2.3.2 Procedure

- The owner must submit full details of the vehicle and its intended use to the relevant permit office;
- The permit office will require the vehicle to be inspected by an engineer or technical representative of the permit office;
- On approval, the permit office will furnish the owner with an official letter stating that the vehicle is a “Special Vehicle”; and
- The owner then submits this letter with the submission for registration on NaTIS.
- When a specially classified abnormal vehicle is registered, the owner must apply for a permit for the unladen vehicle.

2.4 Dimensional and Mass Limitations applicable to Abnormal Load Vehicles

Dimensional and mass limitations applicable to abnormal load vehicles are described in TRH11: “Dimensional and Mass Limitations and Other Requirements for Abnormal Vehicles”.

2.5 Marking and Escorting of Abnormal Load Vehicles

The warning apparatus with which abnormal load vehicles must be marked and requirements for the escorting of abnormal load vehicles are described in TRH11: “Dimensional and Mass Limitations and Other Requirements for Abnormal Vehicles”.

2.6 Speed Restrictions applicable to Abnormal Load Vehicles

The maximum speed at which an abnormal load vehicle is permitted to travel on a public road is described in TRH11: “Dimensional and Mass Limitations and Other Requirements for Abnormal Vehicles”.

2.7 Principle Approvals

The situation where a carrier or manufacturer may find that a particular abnormal vehicle or load may not be granted exemption permits as required can be avoided through the process of principle approval.

2.7.1 Abnormal Vehicles

The purpose of principle approval for an abnormal vehicle is firstly to establish that there is sufficient motivation as to why this particular vehicle needs to be manufactured or imported and operated in conflict with the NRTA, and secondly to confirm the criteria and rules that would be used to evaluate permit applications in the future, should the vehicle be allowed to be manufactured or imported. Besides carrying out technical and traffic impact analyses, the provincial authorities normally consider all historical trip data at their disposal to ascertain the need to approve the use of another similar abnormal vehicle on the road.

Without first attaining principle approval for the manufacturing or importing of an abnormal vehicle, the owner of the abnormal vehicle runs a serious financial risk, as an exemption permit may not be forthcoming from the respective permit office (even though such exemptions will not be withheld unreasonably), or the carrying capacity may be limited to a level where it is not financially viable for the owner to operate the vehicle. It is therefore compulsory to obtain prior approval in principle before an abnormal vehicle is purchased, imported or manufactured.

After receiving the letter of principle approval and proceeding with purchasing, importing or manufacturing the abnormal vehicle, the applicant should not expect the SABS Motor Vehicle Inspectorate to “way leave” standards checks and inspections during the homologation and registration processes. The SABS has a legal obligation to carry out the normal standards checks and vehicle inspections, in terms of their appointment by the Department of Transport. In the event that an abnormal vehicle or truck trailer combination is found to be registered

without having undergone the proper inspections and homologation processes, no abnormal vehicle permit shall be issued until the owner of such a vehicle rectifies the situation.

A letter of application for principle approval must be submitted with a motivation and the necessary supporting data (design, drawings, specifications, etc). The application letter should indicate all the areas of non-compliance with the NRTA and the provisions of the TRH11 Guidelines.

The policy for dealing with principle approvals differs among provinces in South Africa. The applicant is required to follow one of two procedures:

(i) Make an application to the Provincial Transport MEC through the relevant Abnormal Loads Permit Office, who will arrange for a detailed technical evaluation and issue a response; or

(ii) Make an application to the National Regulator for Compulsory Specifications (NRCS) for the homologation of the vehicle. After an inspection of all design drawings, the NRCS issues a letter to the respective province detailing all areas on the proposed vehicle which do not comply with the NRTA. The province concerns then evaluates the proposal and if satisfied that the vehicle will be able to operate under the TRH 11 guidelines, issues a letter to the NRCS indicating that the province has no objection to the issuing of a model number. It is only after this letter is received by the NRCS that the vehicle may be placed on the NaTIS system.

The contact details for the National Regulator for Compulsory Specifications are as follows:

| | |
|-----------------|--|
| Postal Address: | Private Bag X25, Brooklyn 0075 |
| Street Address: | SABS Campus, 1 Dr Lategan Road, Groenkloof. Pretoria |
| Website: | www.nrccs.org.za |
| Telephone: | 012 428 5000 |

In terms of Section 81(1) of the NRTA (as amended by Section 23 of Act 64 of 2008, National Road Traffic Amendment Act, 2008), principle approval will in future be granted by the Minister of Transport. Once this act has been implemented, all applications for principle approval must be submitted to the Minister of Transport through the Department of Transport. It is expected that this will be a delegated mandate to the Deputy Director General: Transport Regulation, Accident & Incident Investigation with the Directorate: Standards Regulation being the responsible unit processing all principle approval applications.

The contact details for the Department of Transport are as follows:

| | |
|---------------------|--|
| Postal Address: | Private Bag X193, Pretoria, 0001 |
| Street Address: | Forum Building, 159 Struben Street, Pretoria |
| Website: | www.dot.gov.za |
| Information office: | 012 309 3000 |

2.7.2 Abnormal Loads

It is voluntary, but advisable, to obtain prior approval in principle before an 'indivisible' item that will need to be transported as an abnormal load is manufactured or imported. The transportation of the item/s should therefore be considered at the design stage. This is especially true when a number of the same items are planned to be manufactured or imported over a period of time.

2.8 Roadworthiness

In terms of the NRTA, no person shall operate a motor vehicle, which is not in a roadworthy condition on a public road. Certification of roadworthiness is further required for certain classes of motor vehicles and the roadworthy certificate must be displayed on the motor vehicle. Vehicles that may only operate on a public road under an exemption in terms of the NRTA are exempted from certification of roadworthiness (Regulation 38 (2)).

The **Error! Reference source not found.** of an abnormal load vehicle(s) will be required to certify that the vehicle is fit for operation on a public road to the limits of his/her inspection before the commencement of the journey. (See Section 5.3 - Control certificate and Standard Permit Condition 21.)

It is one of the primary functions of accredited escorts to inspect every aspect of a vehicle and the permit before commencement of any journey to ensure the safety and roadworthiness of the vehicle.

2.9 Insurance

Before a permit is granted, the carrier may be required to produce evidence that adequate insurance cover has been provided against accidental or wilful damage which may be caused to public services or structures or to private property, either above or below ground

3. ABNORMAL LOAD PERMITS

3.1 Background

The limits recommended in this document are intended to serve as a guide to the permit offices. However, each permit office has the right to refuse a permit application or to specify the conditions under which a permit is granted.

Abnormal load permits are issued at the sole discretion of the permit office. The permit application may be refused because of the condition of the road, the culverts and bridges, the nature of other traffic on the road, abnormally heavy traffic during certain periods or for any other relevant reason.

Application forms for permits are obtainable from the permit offices. Examples of application forms are shown in Appendix A.

A permit can be withdrawn if upon inspection, the vehicle is found to be unfit for operation on a public road.

3.2 Types of Permits

3.2.1 Trip Permits

Trip permits are issued for a single trip or a number of similar trips. Fees are calculated according to the distance travelled. For all trip permits, the periods of validity given in Table 3.1 will apply. When traffic officer escorting is required, the period is increased to 10 days to allow for the extra administration and availability of traffic officers.

Table 3.1: Validity Period for Trip Permits

| Distance (km) | Validity Period (days) |
|---|------------------------|
| Up to 100 | 2 |
| 101 – 250 | 3 |
| 251 – 500 | 4 |
| 501 – 750 | 5 |
| More than 750 | 6 |
| Traffic Officer Escorting required (any distance) | Up to 10 days |

3.2.2 Area-period Permits

Area-period permits are issued for a period of one week up to twelve months and are valid within a prescribed area. The fee depends on the period, the area within which the permit is valid and the type of vehicle and will be calculated on a distance basis as set out in Table 3.2.

The permit area need not be circular with a specified diameter, but, at the discretion of the permit office, it could be an equivalent area, indicating specific centres rather than specific geometric shapes or specific distances.

Table 3.2: Distances for Area-period Permits (km)

| Vehicle category | Operational area | Validity period of permit | | | | |
|---------------------------|------------------|---------------------------|---------|----------|----------|-----------|
| | | 1 week | 1 month | 3 months | 6 months | 12 months |
| Articulated vehicles | 25 km radius | - | 200 | 500 | 850 | 1 500 |
| | 50 km radius | - | 350 | 850 | 1 500 | 2 500 |
| | 100 km radius | - | 500 | 1 200 | 1 800 | 3 000 |
| | Fixed routes | 600 | 2 000 | 5 000 | 9 000 | 18 000 |
| | Province | 800 | 2 400 | 6 400 | 12 000 | 24 000 |
| Emergency repair vehicles | Province | - | - | - | 3 000 | 5 500 |
| Emergency repair cranes | Province | - | - | - | 2 000 | 3 500 |
| Cranes and drilling rigs | 15 km radius | 50 | 150 | 400 | 600 | 1 000 |
| | 30 km radius | 100 | 300 | 700 | 1 200 | 2 000 |
| | 50 km radius | 150 | 450 | 1 050 | 1 800 | 3 000 |
| | 100 km radius | 250 | 750 | 1 750 | 3 000 | 5 000 |
| | Province | 500 | 1 800 | 4 000 | 6 000 | 10 000 |
| Unladen abnormal vehicles | 25 km radius | - | 200 | 500 | 850 | 1 500 |
| | 50 km radius | - | 350 | 850 | 1 500 | 2 500 |
| | 100 km radius | - | 500 | 1 200 | 1 800 | 3 000 |
| | Province | 500 | 1 800 | 4 000 | 6 000 | 10 000 |

The following principles apply to area-period permits:

- Area-period permits are issued per province.
- Area-period permits will not be issued for loads that require more than 1 self escort (vehicles with a width of more than 3.5m do not qualify).
- Area-period permits will not be issued for semi-trailers with a wheelbase that exceeds 12,5m.
- If mass exemption is requested then:
 - Vehicles must be AV registered.
 - Mass exemption will only be considered up to 80 per cent of the maximum AV payload.
 - Mass exemption will only be considered up to a combination mass of 80 000 kg.
- The validity period of permits will be either one week, one month, three months, six months or twelve months
- Table 3.2 will be used to determine the total distance covered in the selected period.
- A list of all plant/items to be carried must accompany the application and will be attached to the permit.

3.2.3 Route-period Permits

Route-period permits are issued for a period of one week to twelve months and are valid for a prescribed route. The fee depends on the period, the length of the route and the type of vehicle. Route-period permits are usually not issued for loads that require traffic officer escorts.

3.3 Countrywide Permits

Countrywide permits are inter-provincial, cross border permits issued by one province on behalf of other provinces, affected by the same abnormal load trip. They are mainly single trip or route-period permits, issued for abnormal loads that do not create a significant risk in terms of the safety of other road users, or have a high impact on the road infrastructure. The aim of countrywide permits is to avoid duplication of administrative procedures by allowing these permits to be issued by one of the affected provinces.

The following principles apply:

- Only loads within categories D1 and D2 will be considered;
- Only trip and route-period permits (3 months maximum) will be considered;
- Only one of the affected provinces i.e. the province of origin, transit or destination may issue the permit;
- No mass exemption will be allowed;
- Laden height will be limited to 4,6 m;
- Loads that require escorting will not be allowed; and
- The wheelbase may not exceed 12,5m.

3.4 Permit Applications

3.4.1 Permit Application and Issuing Procedure

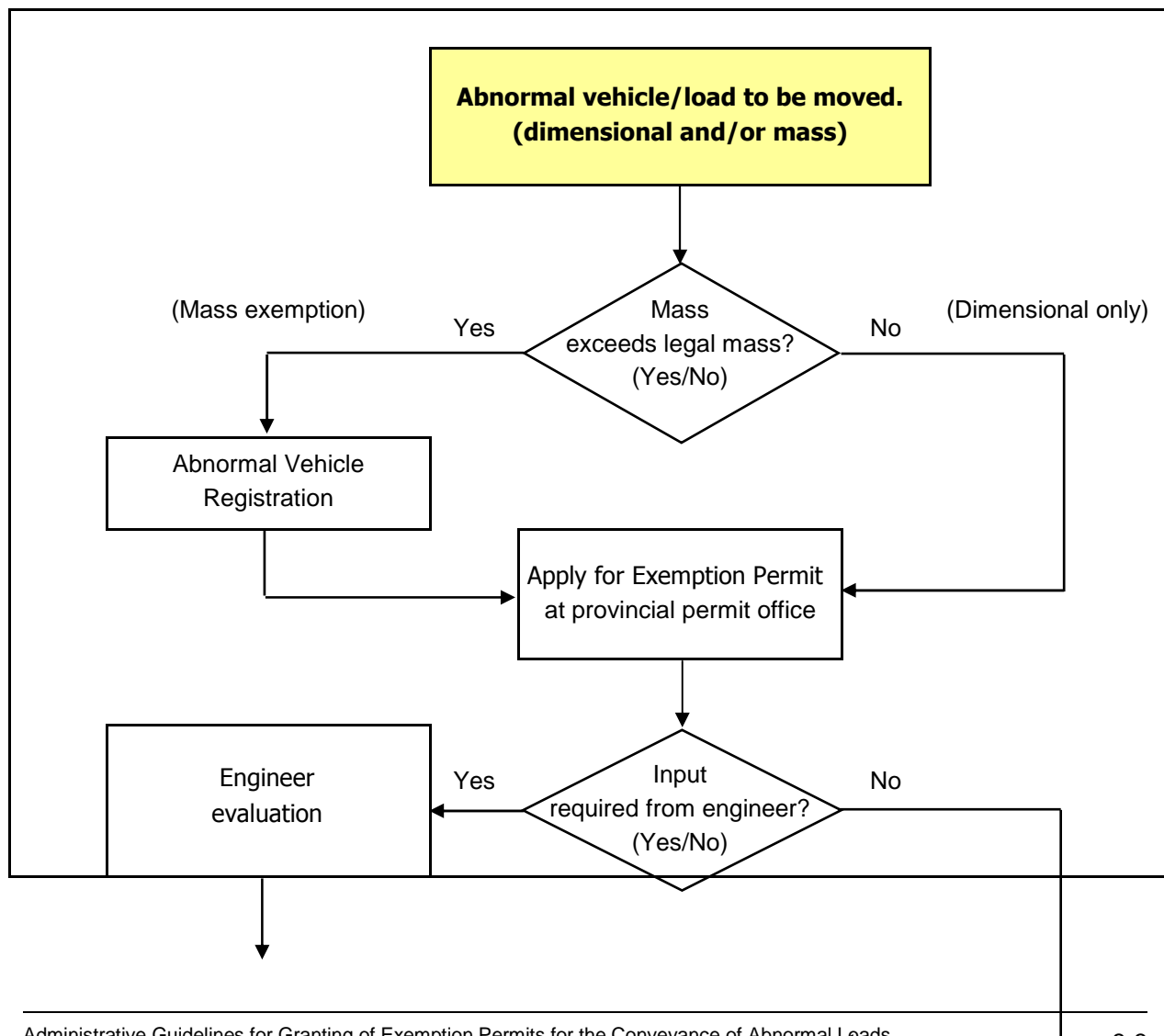

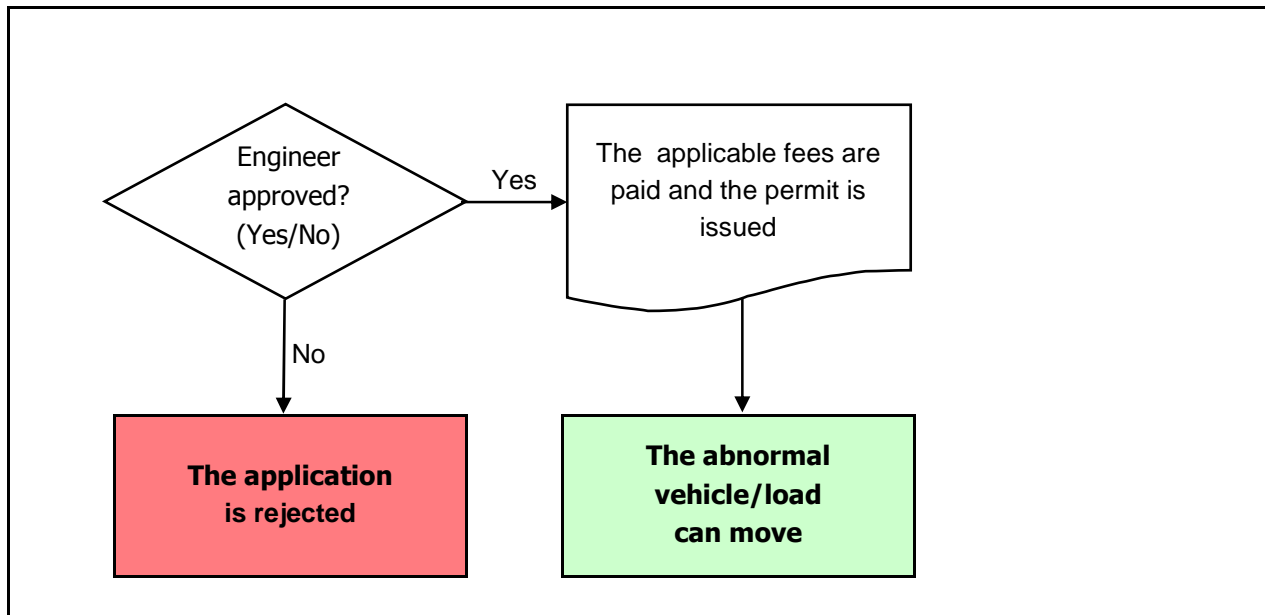

Figure 3.1: Permit Application and Issuing Procedure

3.4.2 Application Documentation

Application for an abnormal load permit is done using the permit application form given in Appendix A or any similar form that will furnish the permit office with all the required data. Other supporting documentation such as route clearances, stability calculations etc. must be supplied as part of the application. The application must be handed in at the relevant permit office for processing.

3.5 Amendment of Exemption Permit

A maximum of three amendments to an issued permit is allowed to cater for permit office errors and/or changes to the permit as requested by the carrier. Fees will only be charged for amendments requested by the carrier.

Amendments that have an influence on the permit fee such as the mass fee, road usage fee and escort fee will result in either an additional amount payable by the carrier or a refund to the carrier.

No amendment shall be considered if the trailer in the combination is replaced by another trailer.

Amendments to permits in terms of the permissible mass are not allowed when a vehicle is weighed at a weighbridge and found not to comply with the mass limits specified on the permit. In such a case a new application must be made and the initial permit (if any) becomes null and void.

3.6 Cancellation of Exemption Permit

3.6.1 Conditions

Only *trip* permits can be cancelled and then only before the start of the exemption period.

3.6.2 Re-imbusement of Fees

Administrative fees (basic fee, fax fee and any other additional fee) are not refundable. Operational permit fees (mass fee, road usage fee and escort fee) are refundable. A cancellation fee (for administration costs) will be levied for this service.

3.6.3 Procedure

- Request the relevant permit office in writing to cancel a permit. The request must include an affidavit, signed by a Commissioner of Oaths, as to the reasons why the permit needs to be cancelled;
- The request must reach the relevant permit office prior to the commencement date of the permit;
- The original permit must accompany the request or must be handed in at a police station. In the latter case, the permit must be handed to the police station prior to the commencement of the permit. The request must be accompanied by an affidavit signed and dated by a Commissioner of Oath stating the date on which the permit was handed in to the police station; and
- The request will be processed by the permit office and the carrier notified of the outcome.

3.7 Embargo Days

During certain periods, such as school holidays or long weekends, an embargo may be placed on the travelling of abnormal vehicles/loads. Some embargoes may only apply to specific routes (corridors) while others may apply to all routes within a province.

A list of embargo days is compiled annually by each province and is obtainable from the relevant permit office as well as from the [Abnormal Loads website](#). Special motivation will be required for exemption from embargo day requirements.

On identified routes in Metropolitan Municipalities, an embargo may be placed on travel between specified times (such as 06:00 to 09:00 and 16:00 to 18:00, either in the peak direction or both directions).

3.8 Weekend Travel

Based on the dual classification system for abnormal loads and routes, defined in TRH 11, the requirements for loads to travel on Saturdays and up to 14:00 on Sundays are as follows:

- On Category A routes: Classes D1 and D2 loads
- On Category B routes: Class D1 loads.

This only applies if the overall height of the load does not exceed 4,6 m and no mass exemption is applicable. Weekend travel is not permitted on Category C and Category D routes.

Until such time that route categories become available, the following interim arrangement will be implemented on a pilot basis: unescorted loads with a width not exceeding 3,35m and height not exceeding 4,6m may be allowed to travel on Saturdays and up to 14:00 on Sundays, on the following routes:

- N1 National Route;
- N2 between Port Shepstone and Richards Bay;
- N3 National Route;
- N4 between Lobatse and Middelburg, Mpumalanga;
- N6 and
- N12 between Three Sisters and Warrenton.

These general requirements may be modified at the discretion of the various issuing authorities to provide for specific circumstances.

Accreditation of a carrier in terms of the Road Traffic Management System (RTMS)² would be considered favourably by the issuing authority when evaluating applications for weekend travel and night travel (see Section 3.9).

3.9 Night Travel

In general, night travel (after sunset and before sunrise) is not allowed for abnormal load vehicles. However, night travel may be permitted at the discretion of the issuing authority under specific conditions, e.g. on routes within metropolitan areas.

3.10 Routes and Clearances

It is the responsibility of the carrier to show that the proposed route and operational procedures of abnormal vehicles or loads are suitable for the intended use. The carrier may, at his own cost, be required to prove that bridges and other structures are capable of accommodating the vehicles or loads for which the exemption permits are applied.

In terms of TRH 11, the requirement for a structural route clearance may be waived when the laden mass of a vehicle or combination of vehicles does not exceed 125 000 kg, provided that the route is specified by the carrier.

² RTMS is an industry-led self-regulation scheme that encourages consignees, consignors and transport operators engaged in the road logistics value chain to implement a vehicle management system that preserves road infrastructure, improves road safety and increases the productivity of the logistics value chain. This scheme also supports the Department of Transport's National Freight Logistics Strategy.

4. FEES

4.1 Background

The registering of abnormal vehicles and the issuing of exemptions permits are administrative functions that attract costs. Furthermore, abnormal vehicles may cause more damage to road pavements and underground services, induce more severe stress in structures and interfere more with traffic flow than legal vehicles. For these reasons, fees will generally be levied to compensate for the administrative costs, costs incurred through the use of public roads by vehicles which do not comply with the requirements of the NRTA and the NRTR and for the cost of traffic officer escorts where required.

The fees payable are made up of one or more of the following.

- (a) Administrative fee for registration and other costs;
- (b) Mass fee and road usage fee; and
- (c) Escort fee.

4.2 Registration Fee

All vehicles and vehicle components that are used to convey abnormally heavy loads as well as overweight mobile cranes must be registered at the permit office (see Section 2.2). A registration fee is levied for this service.

4.3 Administration Fee

A non-recoverable administration fee is levied to cover the cost of issuing a permit. Where input from an engineer is required in the evaluation of the application, a higher administration fee is applicable.

4.4 Road Usage Fee

The road usage fee (T) covers externality costs related to the operation of abnormal load vehicles. These externality costs include congestion cost and environmental aspects such as noise and air pollution.

The formula to calculate the road usage fee is:

$$T = m \times d \times K, \text{ in R/km}$$

| | | | |
|-------|---|---|--|
| where | T | = | road usage fee |
| | m | = | total mass of vehicle/combination of vehicles, in t |
| | d | = | trip distance, in km |
| | K | = | Road Usage Factor, in cents/t-km (determined annually by the ALTC) |

4.5 Mass Fee

The calculation of the mass fee (S) is based on an involved set of relationships between tyre pressures, wheel spacing and axle loading. As a result the total accountable damage (TAD)

factor is calculated by means of a computer program based on current engineering practice. Allowance is made for vehicles that have paid up licenses for normal legal loads. A minimum fee per axle is set annually by the ALTC.

The mass fee, S, is currently calculated on the assumption that the damage caused to a typical road pavement can be expressed as equivalent single wheel mass load elevated to the power of 4,0 and that the total accountable damage, TAD, is the difference between the estimated damage and the allowable damage that is accounted for by the normal license fees and fuel tax.

Therefore

$$S = M \times TAD, \text{ in R/km}$$

where S = mass fee
M = mass factor (as proposed annually by the ALTC)
TAD = total accountable damage factor

4.6 Escorting Fee

Where traffic officers act as accredited escorts, escort fees are levied on a fixed distance fee per traffic officer escort vehicle with minimum amounts per escorting duty. Distances are measured on the same basis as for mass and road usage fees, i.e. the distance travelled by the abnormal load vehicle. In the case of trips that follow routes through urban or industrial areas, the fee may, at the discretion of the permit office, be levied on a time basis.

4.7 Schedule of Fees

The schedule of fees is presented in Table 4.1, which is revised annually after consideration by the Abnormal Loads Technical Committee. The revised fees have to be confirmed by each Provincial Authority individually and become effective at the beginning of each financial year (1 April). Countrywide uniformity of fees is an important principle, and is applied as far as is possible.

Table 4.1: Abnormal Load/Vehicle Fee Items.

| Item | Description of fee | Comment |
|------|--|--|
| 1. | Basic permit fees for permits that require engineering input. (not recoverable) | Administration fee for permits requiring engineer input such as route clearance, GCM exceeds 125 000 kg, stability checks and width exceeds 6,0 m. |
| 2. | Basic permit fees for all other permits (not recoverable) | Administration fee for permits without engineer involvement. |
| 3. | Fee to amend a previously issued permit. | Administration fee. (Up to three amendments allowed). |
| 4. | Permit cancellation fee. | Administration fee. |
| 5. | 1 month period permit fee (area or route) | Fees are levied per province. If it is required to operate in more than one province then the amount will be multiplied by the number of provinces |
| 6. | 3 month period permit fee (area or route) | |
| 7. | 6 month period permit fee (area or route) | |

| Item | Description of fee | Comment |
|------|--|---|
| 8. | 12 month period permit fee (area or route) | involved. |
| 9. | Fax fees | Fee per fax send to other provinces. |
| 10. | Certified permit copy | Fee per extra copy of the permit. |
| 11. | AV registration fee | Fee per vehicle/component registered. |
| 12. | Mass factor, M | Adjusted annually. |
| 13. | Road Usage Factor, K | Adjusted annually. |
| 14. | Provincial escorting fee/vehicle/km | Traffic officer escorting fee. (Distance) |
| 15. | Provincial escorting fee/vehicle/hour | Traffic officer escorting fee. (Time) |
| 16. | Minimum escorting fee/vehicle | When the total fee levied per km is less than this fee then this fee will apply. (short distances) |
| 17. | Weekend escorting fee, per km | If requested by carrier; not refundable if cancelled after the weekend. |
| 18. | Minimum mass fee per axle | Where the calculated mass fee per km is less than this fee times the number of axles, the minimum will apply. |
| 19. | Additional fee for weekend permits | Allowed at the discretion of the permits office only. |
| 20. | 1 month area/period permit fee | Fees are levied per province for empty vehicles. Note that the normal empty leg permit fees are included in the area/period permit fees. (Basic fees are additional). |
| 21. | 3 month area/period permit fee | |
| 22. | 6 month area/period permit fee | |
| 23. | 12 month area/period permit fee | |
| | | |

4.8 Normal Licensing Fee

Vehicles that are not specially classified (see Section 2.3) and are used for the movement of legal loads are liable for the normal licensing fee as determined annually by the provincial authority where the vehicle is registered.

4.9 Other Costs

4.9.1 Prevention of Damage to Structures

In order to ensure the safe passage of an abnormal load or vehicle it may be necessary to investigate, re-build, strengthen or otherwise protect bridges or other structures, or to provide bypasses or drifts. It is the responsibility of the carrier to prove that all proposed procedures and equipment are suitable for the purpose. Any work that may be required will be the responsibility of the carrier and permits shall not be granted until such work and preparations have been completed to the satisfaction of the issuing authority. The cost of repairs of any damage due to the operation will be payable by the carrier.

4.9.2 Fees for Temporary or Permanent Road Alterations, Diversion of Traffic and other Costs

The costs for any special works whether of a temporary or permanent nature, required to allow the load to pass or for diversion of traffic, will be payable by the carrier.

4.10 Carriers Exempted from Fees

All state departments are exempted from the payment of abnormal load fees, but are nevertheless required to apply for abnormal load permits.

5. PERMIT CONDITIONS

5.1 Introduction

In terms of the provisions of Section 81 of the NRTA, an MEC may consider exemption subject to such conditions that he/she may determine for such exemption. The standard permit conditions indicate “**how and when**” abnormal loads can be transported by imposing movement and warning conditions. The purpose of the standard permit conditions is to:

- Regulate the conveyance of abnormal loads;
- Protect the road infrastructure (pavements, bridges and other road infrastructure); and
- Establish a safe environment for other road users.

The standard permit conditions consist of five groups as indicated below:

- Documentation (Conditions 1 to 4) – Note that condition 5 has been removed;
- Movement restrictions (Conditions 6 to 9);
- Warning devices and escorts (Conditions 10 to 17);
- Compliance with existing legislation (Conditions 18 and 19); and
- Responsibilities (Conditions 20 to 23).

Conditions 1(a), 2, 3, 6, 10, 15(a), 15(b), 17, 18, 29, 21, 22, 23, are applicable to all abnormal loads except mobile cranes. Other conditions may be imposed during the evaluation of a permit application. The responsible person must ensure that all permit conditions are adhered to and that the load and dimensions correspond to that reflected on the permit and that the control certificate has been signed.

5.2 Standard Permit Conditions

Table 5.1: Standard Permit Conditions

| No | Description |
|--------|--|
| | DOCUMENTATION |
| 1. (a) | The permit document (original, copy or fax), bearing an original stamp and signature from a provincial permit/traffic office, with a copy of the application form which forms part of the permit, shall be carried in the vehicle at all times, and shown on demand to any authorised officer. |
| 1. (b) | Copies of the abnormal vehicle registration certificates shall be carried in the vehicle at all times, and shown on demand to any authorised officer. |
| 2. | The person in charge (who may be the driver) accompanying the vehicle/load shall complete the control certificate overleaf before the journey is commenced. |
| 3. | All dimensions, mass or other information as mentioned in the application, shall be correct. |
| 4. | The vehicle shall be weighed at the nearest weighbridge and the weighbridge certificate, indicating the mass of each axle and axle unit of the loaded vehicle, shall be kept in the vehicle while the load is being transported. Thereafter, a copy of the permit and the weighbridge certificate(s) shall be forwarded to the issuing office. |

| MOVEMENT RESTRICTIONS | |
|------------------------------|---|
| 5 | <i>(Condition removed)</i> |
| 6. | Vehicle(s) shall not be allowed to obstruct or endanger any other traffic and shall, where necessary, be pulled off the road to allow other traffic to pass. The safety and convenience of other road users shall always receive precedence over that of the vehicle travelling under permit. |
| 7. | The height of every overhead obstruction crossing the roadway shall be determined prior to the vehicle(s) or its load(s) passing there under. If the height of any overhead line is insufficient for the vehicle(s) to clear it, arrangements shall be made with the owner of such overhead lines to have them raised to enable the vehicle/s or load/s to pass. Under no circumstances shall the holder of this permit endeavour to raise any overhead lines, except under the supervision of the owner. |
| 8. | While crossing any bridge, the vehicle shall travel at a uniform speed not exceeding that specified on the permit. The vehicle shall not accelerate on the bridge, neither shall the brakes be applied, nor the gears be changed. The centre of the load shall not be more than 1,0 m (one metre) from the centre line of the bridge roadway. |
| 9. (a) | The vehicle/s shall not be used on a public road on Saturdays, Sundays, Public Holidays or any other dates mentioned in the permit, unless specifically allowed in terms of the permit. |
| 9. (b) | The vehicle/s shall not be used on a public road during the times when lights are required in terms of Regulation 157 of the National Road Traffic Regulations in terms of the National Road Traffic Act, 1996 (Act No. 93 of 1996), unless specifically allowed in terms of the permit. |

| WARNINGS | |
|-----------------|---|
| 10. | Headlamps emitting dipped beams shall be kept burning on all escort vehicles and on the front vehicle of any abnormal vehicle combination requiring warning signs. |
| 11. | The extremities of the abnormal load/vehicle shall be marked by the display of bright red flags to indicate the overall length and width of the vehicle or load. Each flag shall be securely attached to the load or to a staff on the vehicle. The flags shall be placed at the extreme corners of the vehicle or load and shall measure at least 600 mm x 600 mm and shall be clean and free to flutter. |
| 12. (a) | <p>Warning boards attached both to the front and rear of the abnormal vehicle or load must be displayed. In the case of mobile cranes, a warning board must be displayed at the rear only. The warning boards shall be at least 2 000 mm long and 300 mm wide and the background of the warning face of the board shall be white.</p> <p>The warning face shall bear the word "ABNORMAL" in red retro-reflective letters of the modified series E letters, at least 200 mm high.</p> <p>The material used in the manufacturing of the board must comply with the relevant requirements as specified in South African National Standard SANS 1329 "Retro-reflective and fluorescent warning signs for road vehicles, Part 2: Abnormal load vehicle signs".</p> |
| 12. (b) | A speed restriction board, indicating the maximum speed allowed as specified on the permit, shall be fitted above the rear warning sign, as required in |

| | |
|---------|--|
| | condition 12(a). Such sign shall comply with the requirements for a type H sign as specified in South African National Standard SANS 1329 "Retro-reflective and Fluorescent Warning Signs for Road Vehicles", Part 3: "Signs other than triangles, chevron signs and abnormal load vehicle signs". |
| 13. (a) | An amber flashing light shall be fitted on top of the cab of the hauling vehicle, or on the front hauler if there is more than one hauling vehicle. This light shall be in operation at all times when the abnormal vehicle is used on a public road. The visibility distance of the amber flashing light shall be 150 m as specified in Regulation 158(2) of the National Road Traffic Regulations in terms of the National Road Traffic Act, 1996 (Act No. 93 of 1996). |
| 13. (b) | An amber flashing light shall be fitted to the foremost end of the front overhang of a mobile crane, so as to be visible from all sides, and a second amber flashing light shall be fitted to the rear of the mobile crane. The visibility distance of the amber flashing lights shall be 150 m as specified in Regulation 158(2) of the National Road Traffic Regulations in terms of the National Road Traffic Act, 1996 (Act No. 93 of 1996). |
| 14. | <p>The extremities of length, width and height of abnormal loads/vehicles shall be indicated by marker lamps and retro-reflectors. Front-facing lamps shall be green and retro-reflectors shall be white. Rear-facing lamps and retro-reflectors shall be red and side-facing lamps and retro-reflectors shall be amber. The marker lamps shall be switched on at the time specified in Regulation 157 of the National Road Traffic Regulations in terms of the National Road Traffic Act 1996 (Act No. 93 of 1996) and shall remain on during the stipulated periods, unless the abnormal load/vehicle is parked entirely off a public road.</p> <p>The marker lamps and retro-reflectors referred to herein are in addition to the lamps and retro-reflectors specified in Regulations 186 to 192 of the National Road Traffic Regulations in terms of the National Road Traffic Act, 1996 (Act No. 93 of 1996).</p> |
| 15. (a) | If escorting is required and the abnormal vehicle has to travel through a municipal area, excluding on a freeway which does not offer direct access to adjoining properties, the local authority's chief traffic officer shall be informed at least 2 hours beforehand of the arrival of the vehicle. Details of the abnormality as well as the expected time of arrival must be furnished. The instructions of the chief traffic officer must be strictly adhered to. |
| 15. (b) | Persons with red flags (600 mm x 600 mm) shall stand approximately 100 m from both sides of a T-junction and warn oncoming traffic when the vehicle combination enters that T-junction. |
| 16. (a) | <p>The holder of this permit shall provide an approved motor vehicle with an amber flashing light fitted to the roof of the vehicle so as to be visible from all directions. The visibility distance of the amber flashing light shall be 150 m as specified in Regulation 158(2) of the National Road Traffic Regulations in terms of the National Road Traffic Act, 1996 (Act No. 93 of 1996)</p> <p>A warning board with two warning faces shall be fitted to the roof of the escort vehicle. The warning board shall be at least 1 200 mm long by 400 mm high. The background of the warning faces of the board shall be white. The warning faces shall bear the words "ABNORMAL LOAD AHEAD" in retro-reflective red modified series E letters, at least 120 mm high. The material used in the manufacturing of the board must comply with the relevant requirements as specified in South African</p> |

| | |
|---------|---|
| | <p>National Standard SANS 1329 "Retro-reflective and fluorescent warning signs for road vehicles, Part 2: Abnormal load vehicle signs".</p> <p>The warning board must be removable, collapsible or coverable and must not obscure the amber flashing lights referred to above.</p> <p>The vehicle shall also carry, but not normally display, two bright red flags measuring not less than 600 mm x 600 mm, to be used where necessary to warn other traffic of the presence of the abnormal load. The escort vehicle shall travel approximately 250 m behind the abnormal vehicle or at such a distance as directed by a police officer. The duty of the driver of the escort vehicle is to give timely warning to traffic of the presence of the abnormal load/vehicle.</p> |
| 16. (b) | Over and above the vehicle mentioned in Condition 16(a) the holder of this permit shall provide a second similarly equipped escorting vehicle. This vehicle shall drive approximately 250 m ahead of the abnormal vehicle or at such a distance as directed by a police officer. |
| 16. (c) | The vehicle(s) is/are to be escorted by police officers whose instructions shall be obeyed unless such instructions are in conflict with the conditions laid down in the permit. The police officer in charge as specified on the permit shall be advised at least 72 hours before commencement of the journey and all arrangements regarding the escort must be made with this officer. On completion of the journey, the permit shall be handed to the police officer. |
| 16. (d) | The holder of the permit shall provide a vehicle which drives ahead of the abnormal load/vehicle and on which a gauge made of non-conducting material is fitted, with a height of 100 mm more than the maximum height of the abnormal load/vehicle. |
| 17. | All warning signs and flags shall be removed or otherwise obscured and flashing lights, etc. shall be switched off on all vehicles not operating under a permit requiring the use thereof. |

| COMPLIANCE WITH EXISTING LEGISLATION | |
|---|---|
| 18. | This permit does not exempt the holder thereof from complying with any legal requirements other than certain provisions of the National Road Traffic Act of 1996 (Act No. 93 of 1996) and the National Road Traffic Regulations promulgated there under, as implied in the granting of this permit. |
| 19. | Each vehicle in the combination shall have a valid Category A roadworthy certificate which shall be kept in the vehicle at all times. |

| RESPONSIBILITY | |
|-----------------------|---|
| 20. | <p>The holder of this permit or his representative shall ensure that:</p> <ul style="list-style-type: none"> i) the driver of the vehicle is competent to drive the vehicle; ii) the driver, the person in charge and any own escort are fully aware of their duties, and iii) the general and specific conditions of the permit are adhered to. |

| | |
|-----|--|
| 21. | The holder of this permit shall appoint a person in charge (who may be the driver), who shall remain in attendance at all times during which the abnormal load/vehicle is operated on a public road. The person in charge must be a person who has received training in the duties and responsibilities entrusted to him, and shall be the representative and sole agent of the operating body in whose name the permit has been issued for the full period during which the abnormal load/vehicle is on a public road. This person alone shall be in charge of the abnormal load/vehicle and shall be responsible for compliance with the general and specific conditions of this permit. He must be satisfied that the vehicle and load/s thereon are in accordance with the details embodied in the permit, particularly in respect of mass and dimensions. |
| 22. | The holder of this permit shall be responsible for: i) the costs incurred in respect of any visible damage caused as a result of the operation on the road of the abnormal vehicle or load, including the escort vehicle. For instance, a vehicle or load shall not operate on any public road with a bituminous surface when such surface is “bleeding” as a result of hot weather conditions; ii) the speedy removal of the vehicle whenever it caused an obstruction on any public road as well as for the expenses incurred to have the vehicle/s or load/s removed, and iii) costs incurred for any other reason resulting directly or indirectly from the presence of the vehicle or load on any public road as defined in Section 1 of the National Road Traffic Act of 1996 (Act No. 93 of 1996). |
| 23. | Operating of any vehicle/s and/or load/s under this permit shall signify that the holder of this permit indemnifies the Provincial Government against any claims for damages which may arise from the presence of the vehicle/s or load/s on any public road. |

It is important that the person responsible for the transportation of the load has been adequately trained by the owner or his/her representative. The responsible person must check the laden vehicle before departure to ensure that the dimensions correspond to those reflected on the permit. During law enforcement the driver is normally regarded as the responsible person and will be charged if the policy and procedures for transporting abnormal loads are not adhered to.

5.3 Control Certificate

The control certificate must be signed and dated by the person in charge of the abnormal load/vehicle before commencing the journey. Traffic officers must identify the person in charge and verify that the control certificate has been signed by that person. If not, this will be considered a contravention.

| |
|---|
| CONTROL CERTIFICATE |
| I, the person in charge as set out in Condition 21 of the Standard Permit Conditions, hereby certify: |

| | | | |
|-------------------|--|--------------|--|
| i) | that I am fully conversant with all the conditions relevant to this permit and that I will comply with them in all respects; | | |
| (ii) | that the vehicle/s is/are in roadworthy condition, that I have in particular examined the brakes, steering and tyres and found them in good condition and that all defects previously reported have been attended to, to my complete satisfaction, and | | |
| (iii) | that the dimensions, mass and other information on the application form have been checked and are correct. | | |
| SIGNATURE: | | DATE: | |

5.4 Other Conditions

There may be other conditions that the permit office may deem applicable to a permit that are not covered by the standard permit conditions. These could typically include instructions to prevent the use of specific roads where construction is underway, instructions to prevent travel in wet or windy conditions, load securement instructions, specific travel times, special weighing instructions etc. These conditions will be printed on the permit.

6. SPECIFIC POLICIES

6.1 ISO Freight Containers

ISO freight containers are internationally recognized and highly standardized in terms of dimensions. This allows port handling equipment around the world to handle the units efficiently.

A distinction is made between flat-rack and open-top containers, used to facilitate ease of handling of oversized loads such as indivisible machinery, and conventional box containers filled with multiple items. An abnormal load permit may be considered for flat-rack and open-top containers with oversized, abnormal loads provided that the guidelines in TRH11 are met.

Overweight box containers however, may only be moved under permit from the port of entry into South Africa to the nearest depot (maximum distance of 25 km) where the contents can be adjusted. The container is then transported legally to its final destination. The process of granting exemption permits should not influence the normal competition between road and rail.

It should also be kept in mind that there are national law enforcement policies relating to overload control, which deals specifically with overweight freight containers. Abnormal load permits should not be used to undermine the efforts to control heavy vehicle overloading in South Africa. Normal freight containers do not conform to the definition of an abnormal load and therefore do not qualify for special treatment.

6.1.1 Principles

- Long distance permits for flat-rack and open-top containers may be considered and issued in the province where the trip originates.
- Overweight box containers may be transported under permit from the port of entry to a depot where the load can be adjusted to conform to the legal mass limits. (Maximum distance 25 km) Long distance mass permits will not be granted.
- Conditions 9.(a) and 9.(b) (i.e. night and weekend travel restrictions) may be waived for overweight box containers as undue safety and congestion are not considerations
- Height exemption permits may be considered for containers within the legal mass limits with a laden height of up to 4 600 mm.
- Legal ISO containers may not be moved on an abnormal vehicle combination.
- Applications should include the unique reference number displayed on the outer surface of the container so that the container type can be verified.
- A copy of the shipping bill, describing the contents and mass of the container, must accompany the permit application.

6.2 Mobile Cranes

Mobile cranes are classified as non-load carrying vehicles. Mobile cranes usually exceed mass and legal dimension limits, and must therefore be operated under permit. Most mobile cranes are specially classified vehicles and pay a minimum licence fee.

Mobile cranes can be placed in the following three classes:

1. Centre mounted (rough terrain) mobile cranes;
2. Truck mounted mobile cranes; and
3. All terrain mobile cranes.

Centre mounted (rough terrain) mobile cranes are restricted to low travel speeds by the manufacturers and may therefore not be operated on public roads.

6.2.1 Principles

- Mobile cranes with axle masses in excess of the legal limits are liable for mass fees in order to compensate for actual road damage.
- In order to facilitate the issuing of permits all mobile cranes that exceed the legal mass limits must be AV registered;
- The manufacturer's plate must be displayed on the mobile crane;
- Mobile cranes may be allowed to exceed the ESWM limit of 6 500 kg, provided that the axle loads of the mobile crane is limited to 12 000 kg per axle;
- The calculation of the ESWM for fee purposes for mobile cranes is based on the tyre manufacturer's ratings for a speed limit of 60 km/h, with a minimum tyre pressure of 600 kPa;
- Actual mass and tyre pressures as indicated on the AV should be used to calculate the mass fees;
- In the interest of road safety, mobile cranes are not permitted to travel at night.

6.3 Recovery Vehicles

Recovery vehicles fulfil an essential function, but due to the nature of their activities the usual procedure for obtaining exemption permits is usually not appropriate. Therefore special provision is required to cater for their needs.

6.3.1 Principles

The following basic principles apply to all vehicles including recovery vehicles irrespective of size or function:

- The service must be an emergency and in public interest;
- The service is required to be done without delay and may or may not be called for during normal working hours;
- Normal safety standards and manufacturer's ratings apply;
- Legal loads may be exceeded but this must be stated on all permits and permit fees will be calculated accordingly;
- The vehicle(s) must be registered as an abnormal vehicle. In the application the maximum allowable axle masses need to be stated (as selected by the carrier);
- All vehicles must be normally registered and licensed. Scale certificates must be supplied
- Registration numbers of all vehicles must be shown on the permit or attached as a certified copy;
- Application is made for a twelve month period;
- The estimated annual distance travelled by the vehicle(s) under laden conditions will be used to calculate the permit fee. The carrier must satisfy the permit office that the estimate is reasonable;

- The permit shall state that the GCM (manufacturer's rating) of the recovery vehicle may not be exceeded. The minimum traction ratio of 20 per cent shall not be exceeded;
- If the maximum legal combination mass is exceeded or the minimum traction ratio is not attained, the towing vehicle shall not be allowed to travel for a distance of more than 5 km with the towed vehicle(s). (Allowing the distressed vehicle(s) to be towed to a position ensuring the safety of the travelling public only.);
- In the case of dangerous goods such as flammable materials, the distance of 5 km may be exceeded within reason and under the supervision of a traffic officer.

6.4 Extra Wide Loads

Extra wide loads (exceeding 6,4 m in width) present special challenges, as traffic on two-lane roads may be totally disrupted. The need to transport such loads must be carefully established.

The movement of such loads on two-lane roads does not allow following or oncoming traffic to pass. Oncoming traffic presents a particular problem in this regard and significant delays may be caused to general traffic. The situation can be more readily accommodated on multiple lane roads and freeways with ample shoulders.

6.4.1 Principles

- Normal safety standards and manufacturer's ratings will apply;
- Adequate motivation from the designer/manufacturer for the necessity of the extra wide load is required. Transport aspects should be taken into account in the design phase of prefabricated structures/products to prevent extra wide loads. Principle approval for the transport of the loads must be obtained from road authorities at this stage;
- Power and traction ratios are of vital importance and may not be compromised;
- The route must be specified in detail and a route clearance and traffic accommodation plan by an independent engineer is required stating acceptance of full responsibility for the safe transportation of the load;
- The general travelling public must be given prior warning in the press and other media as appropriate;
- Weekend travel restrictions may be waived;
- Convoys of more than one load will not be allowed.

6.5 Car Carriers

Car carriers are used to transport passenger vehicles on the following truck and trailer combinations:

- Truck tractor and semi trailer. (18,5 m overall length)
- Truck tractor plus semi trailer plus "pup" trailer. (22 m overall length)
- Freighter chassis plus trailer. (22 m overall length)

These vehicles and combination of vehicles are not abnormal when unladen. The abnormality is usually related to the height of the laden vehicle and a minor length abnormality, relating to rear load projection.

Passenger vehicles cannot be classified as an abnormal load, as these vehicles can be transported in a safe manner in accordance with the NRTA and the NRTR. However, historically these vehicles have been allowed to operate under an exemption permit allowing a laden height of up to 4 600 mm and a rear load projection of 500 mm.

A decision has therefore been taken to allow existing vehicles to continue to operate under exemption permits under these conditions.

6.5.1 Principles

- Exemption permits will only be issued for vehicles already registered on the Abnormal Permit System at the date of the issuing of this document.
- Car carriers are used on the whole road network and therefore permits need to be issued uniformly, on a countrywide basis.
- As an uncontrolled operation the impact on other motorists, from a road safety point of view, should be limited to the effect that the largest legal vehicle combination, a 22 m interlink, have on traffic.
- Vehicles must be fully licensed. Specially classified vehicles should not be used to transport motorcars.
- Period permits may be granted to car carriers up to a height of 4 600 mm, on a countrywide basis
- The length of the empty car carrier is restricted to 18,5 m for articulated vehicles and 22 m for other combinations of vehicles.
- A rear load projection of 500 mm will be allowed.
- The total laden length of the combination, including the rear load projection is limited 19 m for articulated vehicles and 22,5 m for other combinations of vehicles.
- Mass and all the other dimensions must be legal.

Appendix A: Permit Application Forms

ABNORMAL LOAD/VEHICLE PERMIT APPLICATION

APPLICATION FOR EXEMPTION IN TERMS OF NATIONAL ROAD TRAFFIC ACT, 1996 (ACT 93 OF 1996) SECTION 81

Permit no.
 Ref. no.

1 Application for exemption in terms of the National Road Traffic Act, 1996 (Act 93 of 1996) section 81

2 Mark the applicable block(s) for the Province involved and supply distance of each trip

| | | | | | | | | |
|------------|---------|--------------|---------------|--------------|---------------|------------|------------|---------|
| Free State | Gauteng | Western Cape | Northern Cape | Eastern Cape | Kwazulu Natal | North West | Mpumalanga | Limpopo |
| km | km | km | km | km | km | km | km | km |
| | | | | | | | | |

3 Name and Business address of Carrier

.....
 Telephone

 Contact Person:

4 DETAILS OF LOAD

4.1 Description of loads: If earthmoving or mobile equipment, indicate make and model:

.....

4.2

| | | | |
|-------------|------------|-------------|-----------|
| Length (mm) | Width (mm) | Height (mm) | Mass (kg) |
| | | | |

4.3 Has any portion of the load been removed? If not, state reason:

.....

5 DETAILS OF ABNORMAL LOADED VEHICLE COMBINATION: (AV no:)

5.1.1 Furnish vehicle/combination identification (Registration / A.V no.)

| | | |
|---|----|---|
| <input style="width: 100%;" type="text"/> | or | <input style="width: 100%;" type="text"/> |
| <input style="width: 100%;" type="text"/> | or | <input style="width: 100%;" type="text"/> |

5.1.2 Abnormal vehicle registration numbers

| | | | |
|------------------------------------|------------|------------------------|----------------|
| Truck-tractor(s) or single vehicle | Dolly(ies) | Semi-Trailer / Trailer | Other(specify) |
| | | | |

5.2 Complete below and supply details on a sketch

| | | | | | | |
|-----------------------|------------------|----------------------|----------------|-----------------------|--------------------|-----------------|
| Total Length (mm) | Total width (mm) | Total height (mm) | Wheelbase (mm) | Overhang | | |
| | | | | Front (mm) | Rear (mm) | |
| | | | | | | |
| Front Load Projection | | Rear Load Projection | | Total laden mass (kg) | Total no. of axles | No. of 4 inline |
| Projection (mm) | Height* (mm) | Projection (mm) | Height* (mm) | | | |
| | | | | | | |

* Clear height under projection (if earthmoving or mobile equipment indicate clear height under overhang)

5.3 Does the laden axle mass comply with Regulation 240? Yes No Unladen Permit No.:

5.4 Is the Unladen vehicle/combination abnormal? Yes No

6 TYPE OF PERMIT REQUIRED Distance Route - period Area - period

6.1 Route for which permit is requested / Area of operation:

6.2 Exemption required: from to No. of days

7 I certify that the details given above and on the attached sketch are correct in all aspects and undertake to ensure that the prescribed conditions are strictly adhered to.

Name:

Administrative Officer/Carrier Representative (Signature) ID number: Date

SKETCH

AV No:

8.1 If application is made in respect of a vehicle/combination that differs from the type shown in this sketch, applicant must submit a sketch of the vehicle/combination indicating similar details.

8.2 Indicate axles clearly as follows:

8.2.1 Mark driving axles 

8.2.2 Mark actual axles 

8.2.3 Mark air tag axles 

| | |
|-----------|--|
| Applicant | |
| Address | |
| Load | |

Show the payload schematically on the sketch, showing all dimensions

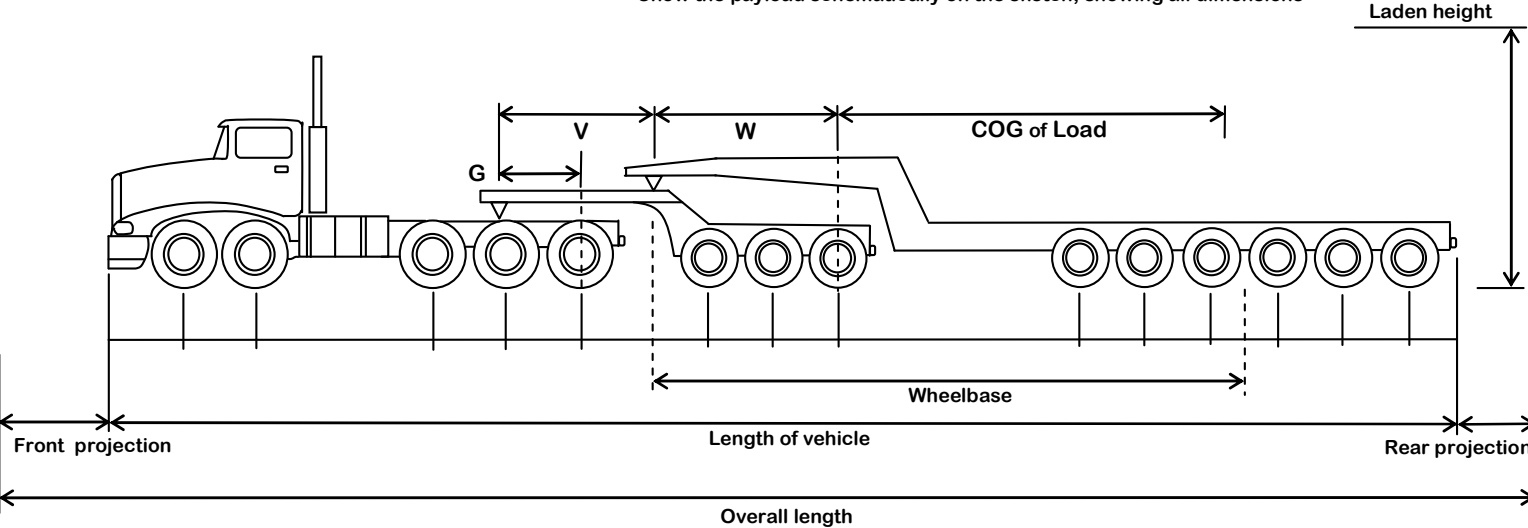

Reg.No:



Reg.No:



Reg.No:

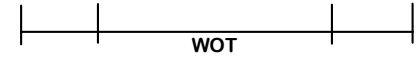

END VIEW

Width of Vehicle

Width of Load

8.3 AXLE TYPE

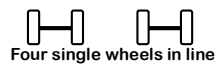
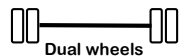
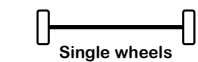

| Axle Unit | Max Mass as per AV (kg) | Gross Mass (kg) | Number of Axles | Axle Type | Tyre Pressure (kPa) | Wheel Spacing (mm) | |
|--------------|-------------------------|-----------------|-----------------|-----------|---------------------|--------------------|-----|
| | | | | | | (a) | (b) |
| Truck Front | | | | | | | |
| Truck Rear | | | | | | | |
| Dolly | | | | | | | |
| Semi Trailer | | | | | | | |
| TOTAL | | | | | | | |

SKETCH

AV No:

8.1 If application is made in respect of a vehicle/combination that differs from the type shown in this sketch, applicant must submit a sketch of the vehicle/combination indicating similar details.

| | |
|-----------|--|
| Applicant | |
| Address | |

8.2 Indicate axles clearly as follows:

8.2.1 Mark driving axles



8.2.2 Mark actual axles



Reg.No:

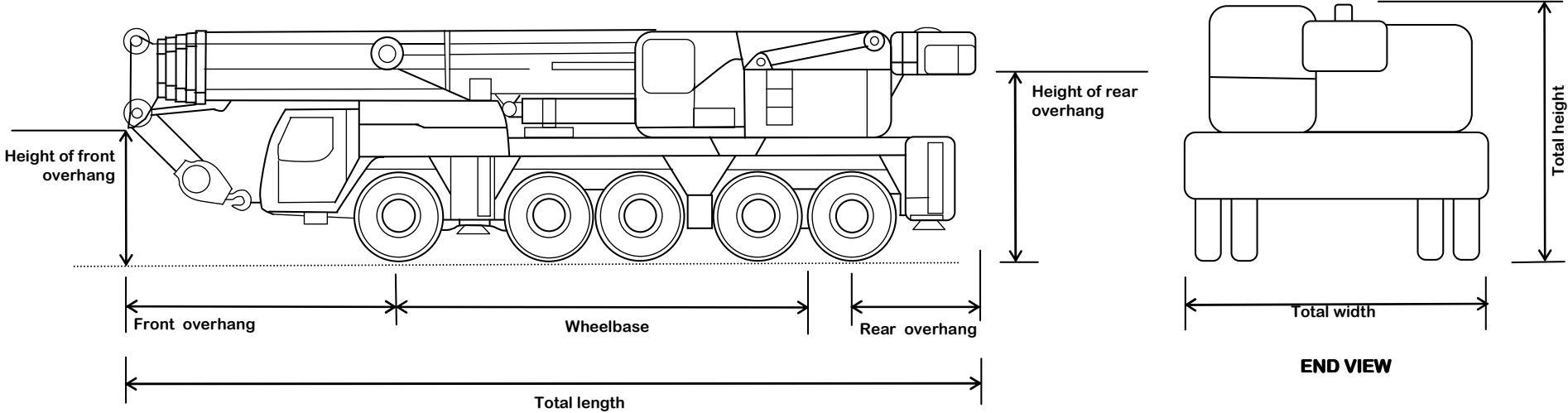

END VIEW

8.3 AXLE TYPE

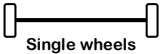

1.

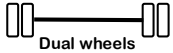

2.

| Axle Unit | Max Mass as per AV (kg) | Gross Mass (kg) | Number of Axles | Axle Type | Tyre Pressure (kPa) | Wheel Spacing (mm) | |
|-----------|-------------------------|-----------------|-----------------|-----------|---------------------|--------------------|-----|
| | | | | | | (a) | (b) |
| 1 | | | | | | | |
| 2 | | | | | | | |
| 3 | | | | | | | |
| 4 | | | | | | | |
| 5 | | | | | | | |
| 6 | | | | | | | |
| TOTAL | | | | | | | |

Appendix B: AV Registration Application Forms

Abnormal Vehicle Registration: TRUCK TRACTOR

| | |
|---------|--|
| Owner | |
| Address | |
| Tel.No. | |

| OFFICIAL USE | |
|--------------|---|
| Seq. No. | 1 |
| Reg. Date | |

| | | | | | | | |
|-----------------|--|-------|--|-----------------------|-------|------|--------|
| Registration No | | Power | | kW | Make | | |
| M.G.C.M. | | kg | | Steering axle driven? | Yes | No | |
| M.G.V.M. | | kg | | Max on 5th Wheel | | kg | |
| | | | | Tag | Front | Rear | Tandem |

| Axle Units | | |
|-------------|-------------------|--------------|
| No of Axles | Unladen Mass (kg) | Ratings (kg) |
| FRONT | | |
| REAR | | |
| TAG | | |

| | |
|--|---|
| *Wheel Codes: Single Dual 4 Single 4 Dual | **Tyre Types: X-Ply Radial Michelin |
|--|---|

| Tyres | | |
|--------------|-----------|-----|
| Tyre Type ** | Tyre Size | Ply |
| | | |
| | | |
| | | |

| Wheel Codes* | | |
|--------------|------|-----|
| FRONT | REAR | TAG |
| | | |

| Dimensions (mm) | | | | | | |
|-----------------|----|---|---|----|----|---|
| A | A1 | B | C | D | E | G |
| | | | | | | |
| N | FW | L | M | TL | TM | |
| | | | | | | |

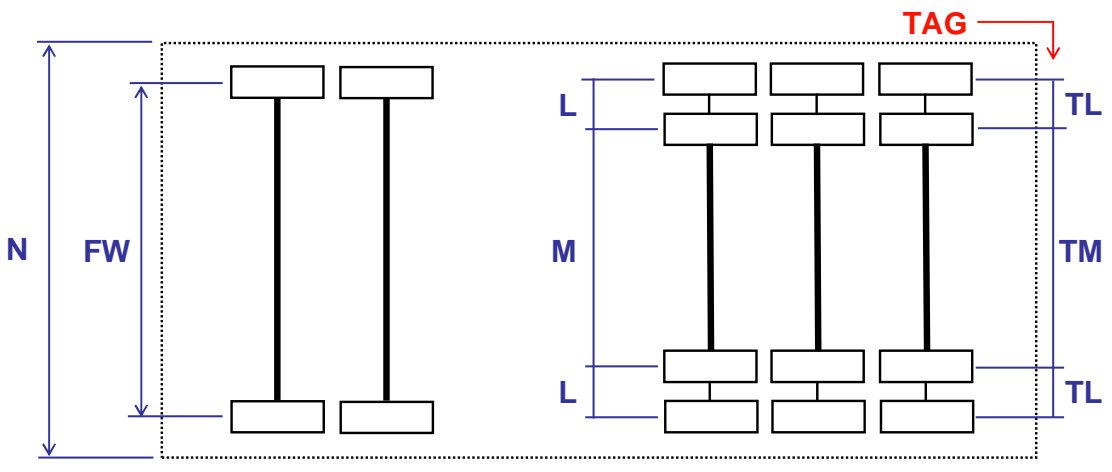
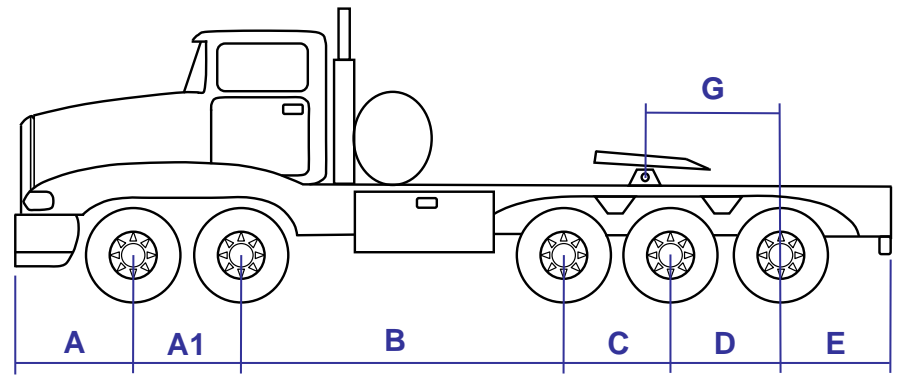

I certify that the details given above are correct in all respects:

Signature: _____ Completed by _____ Owner _____

Date: _____

OFFICIAL USE

Received by: _____

Date: _____

Abnormal Vehicle Registration: DOLLY

Owner

Address

Tel.No.

| OFFICIAL USE | | | | |
|--------------|---|--|--|--|
| Seq. No. | 2 | | | |
| Reg. Date | | | | |

Registration No

Make

Model

Unladen Mass kg

M.G.V.M. kg

Max on 5th Wheel kg

Max load on Kingpin kg

Axles

No of Axles Unladen Axle Unit Mass kg

Axle Unit Rating kg Wheel Code *

| *Wheel Codes: | **Tyre Types: |
|---------------|---------------|
| Single | X-Ply |
| Dual | Radial |
| 4 Single | Michelin |
| 4 Dual | |

Tyres

Tyre Type ** Tyre Size Ply

Dimensions (mm)

| | | | | | | |
|----------------------|----------------------|----------------------|----------------------|----------------------|----------------------|----------------------|
| H | D | E1 | E2 | F | V | W |
| <input type="text"/> | <input type="text"/> | <input type="text"/> | <input type="text"/> | <input type="text"/> | <input type="text"/> | <input type="text"/> |
| R | P | Q | Q1 | | | |
| <input type="text"/> | <input type="text"/> | <input type="text"/> | <input type="text"/> | | | |

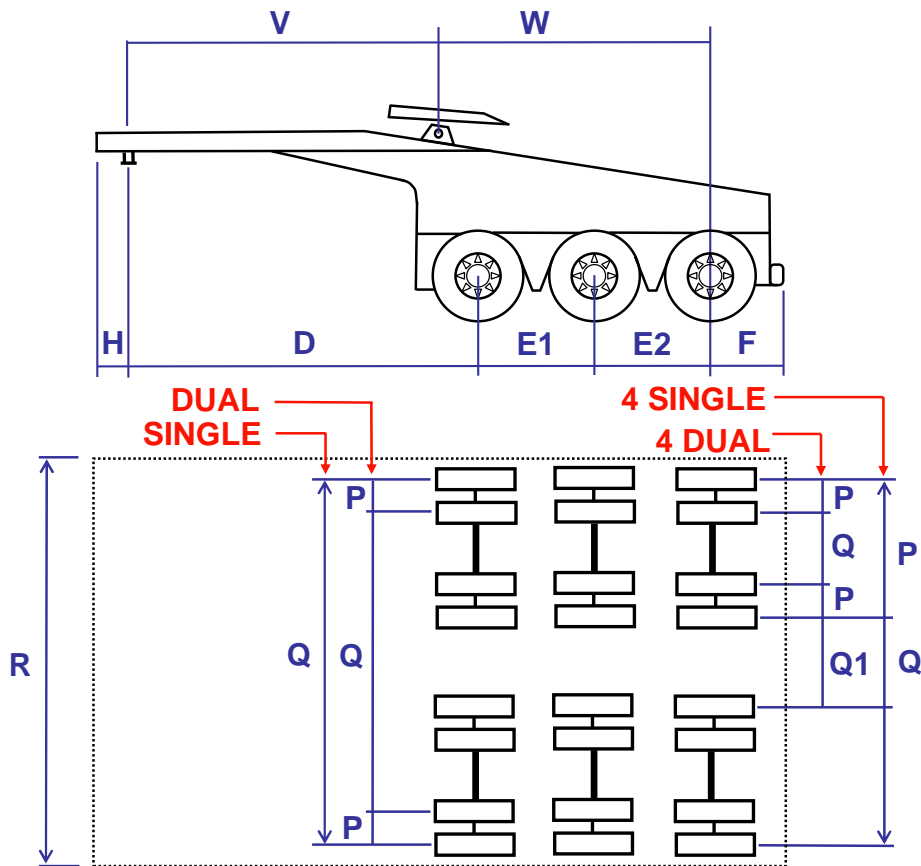

I certify that the details given above are correct in all respects:

Signature: _____ Completed by _____ Owner _____

Date: _____

OFFICIAL USE

Received by: _____

Date: _____

Abnormal Vehicle Registration: MULTI-AXLE TRAILER

Owner:

Address:

Tel. No.:

Registration No:

Make:

Model:

| OFFICIAL USE | | | | |
|--------------|---|--|--|--|
| Seq. No. | 5 | | | |
| Reg. Date | | | | |

Coupling: Towbar Gooseneck (Select)

Rating: kg (Max on Kingpin)

M.G.V.M.: kg

Axle Groups

| Group | No of Axles | Unladen Mass (kn) | Group Rating (kn) | W* Code | Wheel Spacings (mm) | | | Tyre** Type | Tyre Size | Ply | Axle Spacing (mm) | Last Axle to First Axle (mm) |
|-------|-------------|-------------------|-------------------|---------|---------------------|---|---|-------------|-----------|-----|-------------------|------------------------------|
| | | | | | A | B | C | | | | | |
| 1 | | | | | | | | | | | | |
| 2 | | | | | | | | | | | | |
| 3 | | | | | | | | | | | | |
| 4 | | | | | | | | | | | | |
| 5 | | | | | | | | | | | | |
| 6 | | | | | | | | | | | | |

(Distance from Last axle in this group to First axle in next group) _____ ↑

Axles (Use only for non-constant axle spacings)

| Axle No | Group | Dist. to Next Axle | Axle No | Group | Dist. to Next Axle |
|---------|-------|--------------------|---------|-------|--------------------|
| 1 | | | 13 | | |
| 2 | | | 14 | | |
| 3 | | | 15 | | |
| 4 | | | 16 | | |
| 5 | | | 17 | | |
| 6 | | | 18 | | |
| 7 | | | 19 | | |
| 8 | | | 20 | | |
| 9 | | | 21 | | |
| 10 | | | 22 | | |
| 11 | | | 23 | | |
| 12 | | | 24 | | |

Dimensions (mm)

T Tow Point to First Axle

DL Deck Length

DH Deck Height

F Rear Overhang

W Total Width

L Total Length

***Wheel Codes:**

- 1 = Single
- 2 = Dual
- 4 = 4 Singles
- 8 = 4 Duals
- 6 = 6 Duals

****Tyre Types:**

- 1 = Cross-Ply
- 2 = Radial
- 3 = Michelin

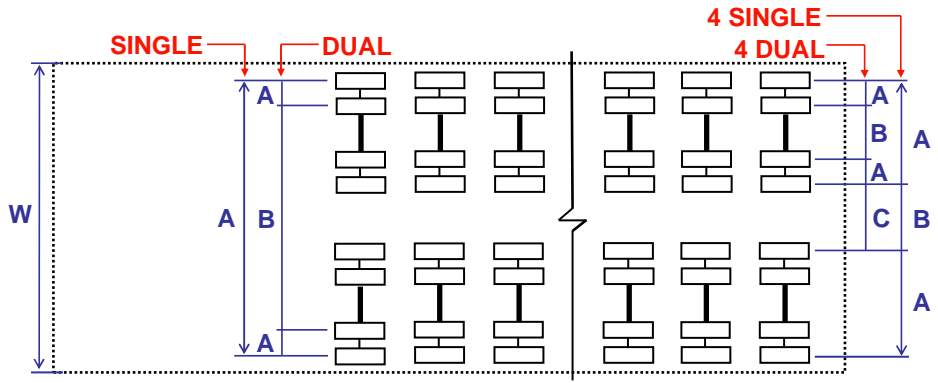
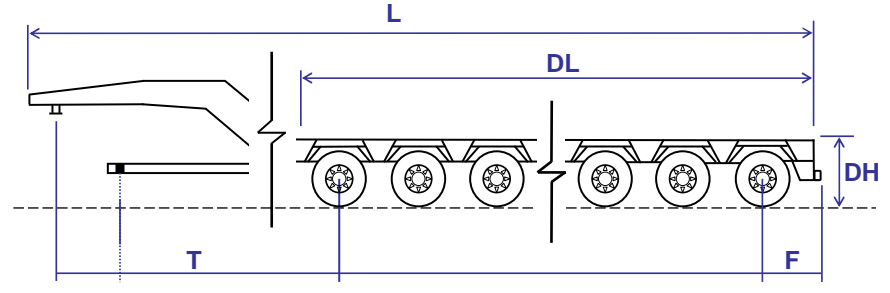

I certify that the details given above are correct in all respects:

Signature: _____

Completed by _____ Owner _____

Date: _____

OFFICIAL USE

Received by: _____

Date: _____

Appendix C: Permit Document Layout

EXEMPTION PERMIT

Issued in terms of Section 81 of the National Road Traffic Act
(Act No. 93 of 1996)



Contact:

Telephone No:

VALIDITY CERTIFICATE

This Permit will be valid from to

SIGNATURE AND CAPACITY

Official Date Stamp

| | |
|------------|--|
| Permit No: | |
| Ref. No: | |
| Job No: | |

PERMIT HOLDER:

Date of Issue:

.....

Time of Issue:

.....

EXEMPTION IS SUBJECT TO THE FOLLOWING:

- Type of Permit:** Trip Area-period Route-period
- Type of Exemption:** Mass Dimensional
- Validity Period:** Days Last Valid Day:
- Vehicle Registration/AV Numbers:**

| Vehicle/Component Type | Registration Number | AV Number (if applicable) |
|------------------------|---------------------|---------------------------|
| | | |
| | | |
| | | |

5. Load Description or Mobile Crane Make & Model:

6. Dimensions of Load and Overall Dimensions of Combination/Mobile Crane (mm):

| | Length | Width | Height | Wheelbase | Overhang | | Load Projection | |
|---------|--------|-------|--------|-----------|----------|-------|-----------------|-------|
| | | | | | Front | Rear | Front | Rear |
| Load | | | | ***** | ***** | ***** | ***** | ***** |
| Overall | | | | | | | | |

7. Route: Route Details or Area of Operation

From:

To:

8. **Escort Requirements:** Number of Own Escorts Number of Official Escorts

9. **Speed Limits (km/h):** Urban Rural Bridges

10. Standard Permit Conditions: (Refer to attached list of conditions for detailed descriptions)

| 1a | 1b | 2 | 3 | 4 | 5 | 6 | 7 | 8 | 9a | 9b | 10 | 11 | 12a | 12b | |
|-----|-----|----|-----|-----|-----|-----|-----|-----|----|----|----|----|-----|-----|----|
| | | | | | | | | | | | | | | | |
| 13a | 13b | 14 | 15a | 15b | 16a | 16b | 16c | 16d | 17 | 18 | 19 | 20 | 21 | 22 | 23 |
| | | | | | | | | | | | | | | | |

ADDENDUM TO EXEMPTION PERMIT



PERMIT HOLDER :

.....

.....

| | |
|------------|--|
| Permit No: | |
| Ref. No: | |

11. Mass of Load and Overall Mass of Combination/Mobile Crane (kg):

| | | | |
|-----------|--|--------------|--|
| Load Mass | | Overall Mass | |
|-----------|--|--------------|--|

12. Axle Groups:

| Axle Group | Max. Permissible Mass (kg) | No of Axles | Axle Type | Tyre Pressure (kPa) | Wheelspace (mm) | |
|------------|----------------------------|-------------|-----------|---------------------|-----------------|-----|
| | | | | | (a) | (b) |
| | | | | | | |
| | | | | | | |
| | | | | | | |
| | | | | | | |

13. Embargo Dates: (No travel permitted on the following days/times)

14. Valid in the following Provinces:

| Eastern Cape | Freestate | Gauteng | KwaZulu Natal | Limpopo | Mpumalanga | Northern Cape | North West | Western Cape |
|--------------|-----------|---------|---------------|---------|------------|---------------|------------|--------------|
| | | | | | | | | |

15. Official Escorts: Arrange at least 72 hours before start of journey (if applicable)

| | | | | | |
|--------------|--|----------|--|---------------|--|
| RTI Station: | | Contact: | | Telephone No: | |
|--------------|--|----------|--|---------------|--|

16. Condition 4 Requirements: (if applicable)

The loaded vehicle is to be weighed and dimensions checked by RTI :

| | | | | | |
|--------------|--|----------|--|---------------|--|
| RTI Station: | | Contact: | | Telephone No: | |
|--------------|--|----------|--|---------------|--|

- Twelve (12) hours notice is to be given to RTI prior to weighing.
- Any excess in mass and/or dimensions are to be reported to this office prior to further movement.
- On completion of the trip the mass-bridge tickets and a copy of this permit are to be immediately submitted to this office.

17. Other Conditions not covered by the Standard Permit Conditions:

.....

.....

.....

18. Permit Fees:

| Mass (c/km) | Length (c/km) | Width (c/km) | Total (c/km) | Distance (km) | Permit Fee |
|-------------|---------------|--------------|--------------|---------------|------------|
| | | | | | |

19. Other Fees:

- Admin Fee
- Escort Fee
- Fax Fee
- Extra Fee

20. Total Fee Payable:

21. Official Receipt Dated For the amount of R Cheque No

**Appendix D: Terms of Reference for the Abnormal Loads
Technical Committee (ALTC)**

BACKGROUND

The National Road Traffic Act (Act 93 of 1996) (herein referred to as the NRTA) and the National Road Traffic Regulations, 2000 (herein after referred to as the NRTR), prescribe certain limitations on vehicle dimensions and axle and vehicle masses with which a vehicle using a public road must comply. However, certain vehicles and loads cannot be moved on public roads without exceeding the limitations in terms of the dimensions and/or mass as prescribed in the NRTR. Where such a vehicle or load cannot be dismantled without disproportionate effort, expense or risk of damage into units that can travel or be transported legally, it is classified as an abnormal load. Provision for such abnormal vehicles and loads is made in Section 81³ of the NRTA, which reads as follows:

“Vehicle and load may be exempted from provisions of Act

81. (1) The Minister may, after the applicant has paid the fees or charges referred to in section 7(3) and subject to such conditions as he or she may determine, authorise in writing, either generally or specifically, the operation on a public road of a vehicle which, due to such vehicle’s original design cannot comply with this Act.

(2) The MEC may, after the applicant has paid the fees or charges referred to in section 7(3) and subject to such conditions as he or she may determine, authorise in writing, either generally or specifically, the conveyance in a safe manner on a public road of passengers or any load otherwise than in accordance with this Act.

(3) An MEC shall determine the fees or charges payable for a vehicle or load that does not comply with this Act.”

The system that has been developed to control and process applications for exemptions from the NRTA, is based on this section of the Act.

A national technical committee, the Abnormal Loads Technical Committee (ALTC) was established in the early 1970's as a steering committee to establish policy and documentation and to control and oversee the granting of exemptions (commonly known as exemption permits) by the (then) four provinces, South West Africa and Zimbabwe. Membership comprised senior engineers representing each province, and the above two neighbouring countries. In due course the need was recognised for the committee to be more representative by including members representing the administration of the permit system and law enforcement officers. At a later stage representatives of the industry were invited to attend a part of committee meetings with the aim of facilitating communication and information flow between government and the private sector.

The policy for the adjudication of applications is contained in a document, “TRH 11 - Dimensional and Mass Limitations and Other Requirements for Abnormal Load Vehicles” (TRH 11), as periodically amended by the ALTC.

The only acceptable grounds for the granting of exemptions are the following:

- Technical feasibility and necessity;
- National emergencies; and

³ As substituted by Section 23 of Act 64 of 2008: National Road Traffic Amendment Act, 2008.

- Economic and/or social interest of the country and public at large.

The ALTC therefore plays an important ongoing role in setting guidelines, fees and standards on behalf of the Minister of Transport and the relevant MECs responsible for transport.

AIM

To promote and co-ordinate the management of adjudicating and processing applications for exemption in terms of Section 81 of the National Road Traffic Act, Act No 93 of 1996 as amended.

OBJECTIVES

- To assist the Department of Transport to develop and update TRH 11 and efficient procedures for the registration of abnormal vehicles and the processing of exemption permit applications;
- To coordinate a national/uniform use and application of TRH 11 and efficient procedures for the registration of abnormal vehicles and the processing of exemption permit applications;
- To provide a forum for discussion amongst representatives of the road authorities and interaction with other stakeholders;
- To ensure acceptable safety standards in terms of all abnormal vehicle/load movements;
- To ensure the protection of the road infrastructure in terms of all abnormal vehicle/load movements;
- To set uniform fees, revised annually, in order to allow the fair and efficient recovery of road wear and administrative costs incurred by the roads authorities;
- To promote the provision and preservation of strategic “super-routes” in terms of dimensions and loading capacity for the movement of superloads; and
- To facilitate sufficient skills transfer in order to ensure the sustainability of the abnormal loads function in terms of TRH 11 within the roads authorities.

MANDATE

The ALTC derives its mandate from the Roads Co-ordination Body (RCB), which reports to the Committee of Transport Officials (COTO), chaired by the Department of Transport. The ALTC also maintains a close working relationship with the Road Traffic Management Coordinating Committee (RTMCC) and the Vehicle Technical Committee (VTC).

FUNCTIONS

The functions of the ALTC are as follows:

- Formulating proposals to improve road safety in respect of vehicle technical issues, and reviewing the proposals of others;
- Formulate guidelines, procedures and administrative policies relating to the movement of abnormal vehicles/loads;
- Provide technical input for the review and updating of TRH 11 and its Administrative Guidelines;
- Ensure uniformity in the application of TRH 11 by all road authorities;
- Annually revise the abnormal load fees;

- Facilitate the maintenance of a database of abnormal vehicle registrations and permits issued;
- Co-ordinate the development and updating of the abnormal loads management system (AVR and AVP software) to be aligned with TRH 11 and the Administrative Guidelines;
- Compile an annual report on abnormal load movements;
- Coordinate awareness of the importance of road safety matters relating to the movement of abnormal loads;
- Facilitate the updating of the “super-routes” map and ensure dissemination of information relating to abnormal load routes;
- Facilitate sufficient skills transfer in order to ensure the sustainability of the abnormal loads function in terms of the TRH 11 within the roads authorities;
- Establish and oversee the ALTC Technical Working Group and other working groups as required;
- Follow a procedure (to be developed) to filter incoming proposals such that only those worthy of the committee’s attention are placed on the Agenda; and
- Ensure that the proposals do not conflict with the legislation of other.

COMPOSITION OF THE ALTC

Representation on the ALTC will be by invitation from the Department of Transport after agreement by members, and will be aimed at forming some balance between regulators (provincial permit office representatives, law enforcement authorities, and structural, traffic & road engineers). The chairperson and secretariat is provided by the Department of Transport. The membership of the ALTC Administration committee consists of representatives from:

- Department of Transport (2 representatives);
- Provincial road authorities (2 members per province);
- Metropolitan/local road authorities (1 representative from SALGA);
- RTMC (2 representatives);
- SANRAL (1 representative);
- Toll concessionaires (1 representative);
- Law enforcement (2 representatives);
- CSIR (1 representative); and
- SABS (1 representative).

It is recommended that provincial road authorities have both technical and administrative representatives on the ALTC.

The structure of the ALTC meetings is such that provision is made for relevant stakeholders (such as industry representatives) to attend, by invitation, a part of the meeting to present issues for consideration by the committee. This practice allows for ongoing interaction and information sharing between industry representatives and the road authorities and to facilitate fair and reasonable decisions by the ALTC.

Membership and participation by neighbouring countries in the SADC Region are also encouraged.

In exceptional circumstances the Chairperson may invite a representative(s) to make presentations on specific products, technology or developments (related to abnormal vehicles) at a committee meeting, but under normal circumstances such presentations shall be made by circulation of documentation to members.

FREQUENCY OF MEETINGS

National meetings of the ALTC are held biannually, usually in March and September each year.

ROTATION OF MEETINGS

Each province has an opportunity to host an ALTC meeting. However, in order to reduce transportation costs, meetings are held more frequently in major transport hubs.

REPORTS AND MINUTES

The chairperson or secretariat of the ALTC will compile the minutes at the end of each ALTC meeting. The minutes will be made available within two weeks after each meeting. The chairperson or secretariat of the ALTC will report to the RCB and keep the RTMCC updated on the developments and status of the ALTC meetings. The provincial representatives will report back to their principals after each ALTC meeting. All ALTC members carry the responsibility to provide relevant feedback of ALTC activities in the respective forums or meetings they attend, for example at the Law Enforcement Technical Committee, Vehicle Technical Committee, National Overload Control Technical Committee, and Legislation Technical Committee.

WORKING GROUPS

Working Groups are appointed by the ALTC whenever specific problems are encountered that need specialised input. The findings and recommendations of these working groups are discussed and ratified at meetings of the ALTC. These may include the Super-route Working Group, the Training Working Group and the more general Technical Working Group.

PUBLICATIONS

The ALTC is responsible for ensuring the publication of the following documents:

- Minutes of all ALTC and ALTC Working Group meetings;
- Annual reports on abnormal load movements in South Africa including the consolidation of statistics from all provinces;
- Abnormal load fees (updated annually); and
- List of embargo days per province (updated annually).

In addition, the ALTC is responsible to advise the Department of Transport on any specific needs to update the following documents:

- TRH11 - Dimensional and Mass Limitations and Other Requirements for Abnormal Load Vehicles; and

- Administrative Guidelines for Granting of Exemption Permits for the Conveyance of Abnormal Loads.

FUNDING

The activities of the ALTC and its working groups are funded by participating members. Members attending meetings are funded by their own respective organisations. The host provides the venue and refreshments for ALTC and ALTC Working Group meetings.

Particular projects such as the development of the software for the processing of permits were funded by individual provinces. Upgrading and maintenance of software is paid for by each province as the need arises.

It is envisaged that future major or specific projects identified to meet the objectives of these Terms of Reference will be funded nationally as it will be in the national interest.

Abnormal Loads website:

www.abnormalloads.co.za